

Marking Scheme
Class X Session 2024-25
MATHEMATICS STANDARD (Code No.041)

TIME: 3 hours

MAX.MARKS: 80

Q.No.	Section A	Marks
1.	D) -6,6	1
2.	B) -5	1
3.	D) From a point inside a circle only two tangents can be drawn.	1
4.	A) 7	1
5.	B) 20 cm	1
6.	A) $\frac{11}{9}$	1
7.	C) 140°	1
8.	B) $8x^2 - 20$	1
9.	C) 30	1
10.	B) isosceles and similar	1
11.	A) Irrational and distinct	1
12.	C) $\frac{3}{\sqrt{3}}$	1
13.	B) $\frac{594}{7}$	1
14.	B) $\frac{3}{8}$	1
15.	B) (-4, 0)	1
16.	A) median	1
17.	C) (3,0)	1
18.	D) $\frac{3}{26}$	1
19.	B)	1
20.	D)	1

Section B		
21. (A)	$480 = 2^5 \times 3 \times 5$ $720 = 2^4 \times 3^2 \times 5$ LCM (480,720) = $2^5 \times 3^2 \times 5 = 1440$ HCF (480, 720) = $2^4 \times 3 \times 5 = 240$	$\frac{1}{2}$ $\frac{1}{2}$ $\frac{1}{2}$ $\frac{1}{2}$
	OR	
(B)	$85 = 5 \times 17, 238 = 2 \times 7 \times 17$ HCF(85, 238) = 17 $17 = 85x - 238y$ $m = 3$	1 1
22.(A)	Total number of possible outcomes = $6 \times 6 = 36$ For a product to be odd, both the numbers should be odd. Favourable outcomes are (7,7) (7,9) (7,11) (9,7) (9,9) (9, 11) (11,7) (11,9) (11,11) no. of favourable outcomes = 9 P (product is odd) = $\frac{9}{36}$ OR $\frac{1}{4}$	$\frac{1}{2}$ 1 $\frac{1}{2}$
	OR	
(B)	Total number of three-digit numbers = 900. Numbers with hundredth digit 8 & and unit's digit 5 are 805,815, 825,.....,895 Number of favourable outcomes = 10 P(selecting one such number) = $\frac{10}{900}$ OR $\frac{1}{90}$	$\frac{1}{2}$ 1 $\frac{1}{2}$
23.	$\frac{2 \left(\frac{\sqrt{3}}{2}\right)^2 - \left(\frac{1}{\sqrt{3}}\right)^2}{(\sqrt{2})^2}$ $= \frac{7}{12}$	$1 \frac{1}{2}$ $\frac{1}{2}$
24	Let the required point be (x,0) $\sqrt{(8-x)^2 + 25} = \sqrt{41}$ $\Rightarrow (8-x)^2 = 16$ $\Rightarrow 8-x = \pm 4$ $\Rightarrow x = 4, 12$ Two points on the x-axis are (4,0) & (12,0).	$\frac{1}{2}$ $\frac{1}{2}$ 1

	$\Delta AQR \sim \Delta ACD$ $\Rightarrow \frac{AQ}{AC} = \frac{RQ}{DC} \dots\dots\dots (ii)$ Now, $\frac{AP}{AB} = \frac{AQ}{AC} \dots\dots\dots(iii)$ Using (i), (ii) & (iii), $\frac{PR}{BD} = \frac{RQ}{DC}$ But, $BD = DC$ $\Rightarrow PR = RQ$ or AD bisects PQ	1 1
27.	Let the numbers be x and 18-x. $\frac{1}{x} + \frac{1}{18-x} = \frac{9}{40}$ $\Rightarrow 18 \times 40 = 9x(18-x)$ $\Rightarrow x^2 - 18x + 80 = 0$ $\Rightarrow (x-10)(x-8) = 0$ $\Rightarrow x = 10, 8.$ $\Rightarrow 18-x = 8, 10$ Hence two numbers are 8 and 10.	$\frac{1}{2}$ 1 1 $\frac{1}{2}$
28.	From given polynomial $\alpha + \beta = \frac{5}{6}, \alpha\beta = \frac{1}{6}$ $\alpha^2 + \beta^2 = \left(\frac{5}{6}\right)^2 - 2 \times \frac{1}{6} = \frac{13}{36}$ And $\alpha^2 \beta^2 = \left(\frac{1}{6}\right)^2 = \frac{1}{36}$ $x^2 - \frac{13}{36}x + \frac{1}{36}$ \Rightarrow Required polynomial is $36x^2 - 13x + 1$	1 1 $\frac{1}{2}$ $\frac{1}{2}$
29.	$(\cos\theta + \sin\theta)^2 + (\cos\theta - \sin\theta)^2 = 2(\cos^2\theta + \sin^2\theta) = 2$ $\Rightarrow (1)^2 + (\cos\theta - \sin\theta)^2 = 2$ $\Rightarrow (\cos\theta - \sin\theta)^2 = 1$ $\Rightarrow \cos\theta - \sin\theta = \pm 1$	$1 \frac{1}{2}$ 1 $\frac{1}{2}$
30.(A)	Angle described by minute hand in 5 min = 30° . length of minute hand = 18 cm = r. Area swept by minute hand in 35 minutes $= \left(\frac{22}{7} \times 18 \times 18 \times \frac{30}{360}\right) \times 7$ $= 594 \text{ cm}^2.$ OR	2 1
(B)	Area of minor segment = Ar. Sector OAB - Ar. Δ OAB $= \frac{60}{360} \times \frac{22}{7} \times 14 \times 14 - \frac{\sqrt{3}}{4} \times 14 \times 14$ $= 17.89 \text{ cm}^2$	2 1

31.	<p>Let $\sqrt{3}$ be a rational number.</p> <p>$\therefore \sqrt{3} = \frac{p}{q}$, where $q \neq 0$ and let p & q be co-prime.</p> <p>$3q^2 = p^2 \Rightarrow p^2$ is divisible by 3 $\Rightarrow p$ is divisible by 3 ----- (i)</p> <p>$\Rightarrow p = 3a$, where 'a' is some integer</p> <p>$9a^2 = 3q^2 \Rightarrow q^2 = 3a^2 \Rightarrow q^2$ is divisible by 3 $\Rightarrow q$ is divisible by 3----- (ii)</p> <p>(i) and (ii) leads to contradiction as 'p' and 'q' are co-prime.</p>	<p>$\frac{1}{2}$</p> <p>1</p> <p>1</p> <p>$\frac{1}{2}$</p>
Section D		
<p>32.(A)</p> <p>(B)</p>	<p>$x+2y=3, 2x-3y+8=0$ Correct graph of each equation Solution $x=-1$ and $y=2$</p> <p>OR</p> <p>Let car I starts from A with speed x km/hr and car II Starts from B with speed y km/hr ($x > y$)</p> <p>Case I- when cars are moving in the same direction. Distance covered by car I in 9 hours = $9x$. Distance covered by car II in 9 hours = $9y$ Therefore $9(x-y) = 180$ $\Rightarrow x-y = 20$ (i)</p> <p>case II- when cars are moving in opposite directions.</p> <p>Distance covered by Car I in 1 hour = x Distance covered by Car II in 1 hour = y</p> <p>Therefore $x + y = 180$ (ii) Solving (i) and (ii) we get, $x = 100$ km/hr, $y = 80$ km/hr.</p>	<p>$2+2 = 4$</p> <p>1</p> <p>2</p> <p>2</p> <p>1</p>
33.	<p>Correct given, to prove, construction, figure</p> <p>Correct proof</p> <p>$AR = AQ = 7$cm $BP = BR = AB - AR = 3$cm $CP = CQ = 5$cm $BC = BP + PC = 3 + 5 = 8$ cm</p>	<p>1</p> <p>2</p> <p>$\frac{1}{2}$</p> <p>$\frac{1}{2}$</p> <p>$\frac{1}{2}$</p> <p>$\frac{1}{2}$</p>

34.

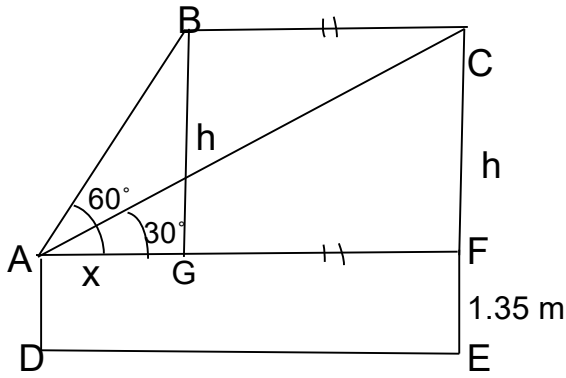

Let A be the eye level & B, C are positions of balloon
 Distance covered by balloon in 12 sec = $3 \times 12 = 36$ m
 $BC = GF = 36$ m

$$\tan 60^\circ = \sqrt{3} = \frac{h}{x}$$

$$\Rightarrow h = x \sqrt{3} \dots\dots (i)$$

$$\tan 30^\circ = \frac{1}{\sqrt{3}} = \frac{h}{x+36}$$

$$\Rightarrow h = \frac{x+36}{\sqrt{3}} \dots\dots (ii)$$

Solving (i) and (ii) $h = 18\sqrt{3} = 31.14$ m
 Height of balloon from ground = $1.35 + 31.14 = 32.49$ m

Correct figure 1mark

1

1

1

1

35.

Class	x	f	$u = \frac{x-102.5}{5}$	fu	cf
85-90	87.5	15	-3	-45	15
90-95	92.5	22	-2	-44	37
95-100	97.5	20	-1	-20	57
100-105	102.5	18	0	0	75
105-110	107.5	20	1	20	95
110-115	112.5	25	2	50	120
		$\Sigma f = 120$		$\Sigma fu = -39$	

$$\text{Mean} = \bar{x} = 102.5 - 5 \times \frac{39}{120}$$

$$= 100.875$$

Median class is 100-105

$$\text{Median} = 100 + \frac{5}{18} (60-57) = 100.83$$

OR

Correct table 2marks

1
 $\frac{1}{2}$
 $\frac{1}{2}$
 1

Monthly Expenditure	f_i	x_i	$f_i x_i$	Correct table 2marks
1000-1500	24	1250	30,000	
1500-2000	40	1750	70,000	
2000-2500	33	2250	74,250	
2500-3000	X=28	2750	77,000	
3000-3500	30	3250	97,500	
3500-4000	22	3750	82,500	
4000-4500	16	4250	68,000	
4500-5000	7	4750	33,250	
$172+x=200$ $X=28$ $\text{Mean} = \frac{532500}{200}$ $= 2662.5$				1 1 1
Section E				
36.(i)	First term $a = 3$, A.P is 3, 6, 9, 12.....,24 common difference $d = 6-3 = 3$			$\frac{1}{2}$ $\frac{1}{2}$
(ii)	$34 = 3 + (n-1)3$ $\Rightarrow n = \frac{34}{3} = 11\frac{1}{3}$ which is not a positive integer. Therefore, it is not possible to have 34 jars in a layer if the given pattern is continued.			$\frac{1}{2}$ $\frac{1}{2}$
(iii)(A)	$S_n = \frac{n}{2} [2 \times 3 + (n-1) 3]$ $= \frac{n}{2} [6 + 3n-3]$ $= \frac{n}{2} [3+3n]$ $= 3 \frac{n}{2} [1+n]$ $s_8 = 3 \times \frac{8}{2} (1+8)$ $= 108$			$\frac{1}{2}$ 1
	OR			
(iii) (B)	A.P will be 6, 9, 12, $a = 6, d = 3$			$\frac{1}{2}$
	$t_5 = 6 + (5-1)3$ $= 6 + 12$ $= 18$			1 $\frac{1}{2}$
37. (i)	$\angle DPQ = \angle DEF$			
	$\angle PDQ = \angle EDF$			
(ii)	Therefore $\Delta DPQ \sim \Delta DEF$			1
	$DE = 50 + 70 = 120 \text{ cm}$			$\frac{1}{2}$
	$\frac{DP}{DE} = \frac{PQ}{EF}$			

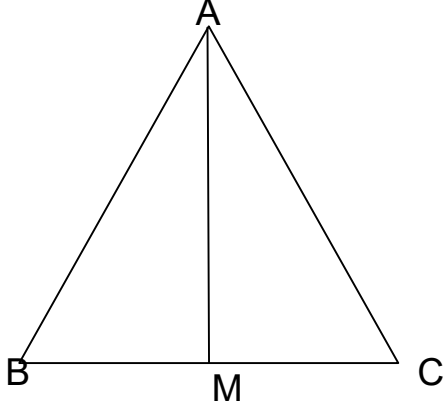
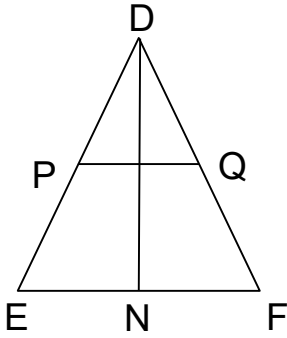
(iii) (A)	<p>Therefore $\frac{PQ}{EF} = \frac{50}{120}$ or $\frac{5}{12}$</p> $\frac{AB}{DE} = \frac{5}{2} = \frac{BC}{EF} = \frac{AC}{DF}$ $\Rightarrow AB = \frac{5}{2} DE$ $\frac{\text{perimeter of } \triangle ABC}{\text{perimeter of } \triangle DEF} = \frac{\frac{5}{2}(DE + EF + FD)}{DE + EF + FD} = \frac{5}{2} \text{ (Constant)}$ <p style="text-align: center;">OR</p> <div style="display: flex; justify-content: space-around; align-items: center;"> <div style="text-align: center;">  <p>$\frac{AB}{DE} = \frac{BC}{EF} = \frac{BC/2}{EF/2} = \frac{BM}{EN}$</p> <p>Also $\angle B = \angle E$</p> <p>Therefore $\triangle ABM \sim \triangle DEN$.</p> </div> <div style="text-align: center;">  </div> </div>	<p>$\frac{1}{2}$</p> <p>1</p> <p>1</p> <p>Correct fig. $\frac{1}{2}$ mark</p> <p>1</p> <p>$\frac{1}{2}$</p>
38. (i)	$l = \sqrt{r^2 + h^2}$ $= \sqrt{(1.5)^2 + (2)^2}$ $= \sqrt{2.25 + 4}$ $= \sqrt{6.25}$ $= 2.5 \text{ m}$	<p>$\frac{1}{2}$</p> <p>$\frac{1}{2}$</p>
(ii)	<p>CSA of cone = $\pi r l$</p> $= \frac{22}{7} \times 1.5 \times 2.5$ $= 11.78 \text{ m}^2$	<p>$\frac{1}{2}$</p> <p>$\frac{1}{2}$</p>
(iii) (A)	<p>CSA of cylinder = $2\pi r h$</p> $= 2 \times \frac{22}{7} \times 1.5 \times 7$ $= 66 \text{ m}^2$ <p>Cost of metal sheet used = 66×2000</p> $= ₹1,32,000$	<p>1</p> <p>1</p>
(iii) (B)	<p style="text-align: center;">OR</p> <p>Volume of cylinder = $\pi r^2 h$</p> $= \frac{22}{7} \times (1.5)^2 \times 7$ $= 49.5 \text{ m}^3$	<p>$\frac{1}{2}$</p>

	<p>Volume of cone = $\frac{1}{3} \pi r^2 h$ $= \frac{1}{3} \times \frac{22}{7} \times (1.5)^2 \times 2$ $= 4.71 \text{ m}^3$</p> <p>Total capacity = $49.5 + 4.71 = 54.21 \text{ m}^3$</p>	<p>1</p> <p>$\frac{1}{2}$</p>
--	--	--