

9. Elements of Groups 13, 14 and 15



Can you recall?

If the valence shell electronic configuration of an element is $3s^23p^1$ in which block of periodic table is it placed ?

9.1 Introduction : You have learnt in Chapter 7 that in the p-block elements the differentiating electron (the last filling electron) enters the outermost p orbital. You also know that maximum six electrons can be accommodated in p-subshell (or three p orbitals). This gives rise to six groups, group 13 to 18, in the p-block. The p-block elements show greater variation in the properties than 's' block, which you learnt in the previous chapter. In this chapter you are going to study the elements of the groups 13, 14 and 15 in some details.

The elements boron (${}_5\text{B}$), aluminium (${}_{13}\text{Al}$), gallium (${}_{31}\text{Ga}$), indium (${}_{49}\text{In}$) and thallium (${}_{81}\text{Tl}$) constitute the group 13, called the **boron family**. The elements carbon (${}_6\text{C}$), silicon (${}_{14}\text{Si}$), germanium (${}_{32}\text{Ge}$), tin (${}_{50}\text{Sn}$)

and lead (${}_{82}\text{Pb}$) form the group 14 called the **carbon family**. The elements nitrogen (${}_7\text{N}$), phosphorous (${}_{15}\text{P}$), arsenic (${}_{33}\text{As}$), antimony (${}_{51}\text{Sb}$) and bismuth (${}_{83}\text{Bi}$) belong to group 15 of the periodic table called the **nitrogen family**.

9.2 Electronic configuration of elements of groups 13, 14 and 15

The general outer electronic configuration of the group 13 elements is ns^2np^1 , those of the group 14 elements is ns^2np^2 while the group 15 elements are shown as ns^2np^3 . These electronic configurations differ from their nearest inert gas by 3 or 4 electrons. These elements do not occur in free monoatomic state and found as compounds with other elements or as polyatomic molecules (such as N_2 , P_4 , C_{60}) or polyatomic covalent arrays (such as graphite, diamond). Table 9.1 shows the condensed electronic configuration of the elements of group 13, group 14 and group 15.

Table 9.1 : Condensed electronic configuration of elements of groups 13, 14 and 15

Group 13 (Boron family)		Group 14 (Carbon family)		Group 15 (Nitrogen family)	
Element	Condensed electronic configuration	Element	Condensed electronic configuration	Element	Condensed electronic configuration
${}_5\text{B}$	$[\text{He}]2s^22p^1$	${}_6\text{C}$	$[\text{He}]2s^22p^2$	${}_7\text{N}$	$[\text{He}]2s^22p^3$
${}_{13}\text{Al}$	$[\text{Ne}]3s^23p^1$	${}_{14}\text{Si}$	$[\text{Ne}]3s^23p^2$	${}_{15}\text{P}$	$[\text{Ne}]3s^23p^3$
${}_{31}\text{Ga}$	$[\text{Ar}]3d^{10}4s^24p^1$	${}_{32}\text{Ge}$	$[\text{Ar}]3d^{10}4s^24p^2$	${}_{33}\text{As}$	$[\text{Ar}]3d^{10}4s^24p^3$
${}_{49}\text{In}$	$[\text{Kr}]4d^{10}5s^25p^1$	${}_{50}\text{Sn}$	$[\text{Kr}]4d^{10}5s^25p^2$	${}_{51}\text{Sb}$	$[\text{Kr}]4d^{10}5s^25p^3$
${}_{81}\text{Tl}$	$[\text{Xe}]4f^{14}5d^{10}6s^26p^1$	${}_{82}\text{Pb}$	$[\text{Xe}]4f^{14}5d^{10}6s^26p^2$	${}_{83}\text{Bi}$	$[\text{Xe}]4f^{14}5d^{10}6s^26p^3$

Problem 9.1 : Atomic numbers of the group 13 elements are in the order $\text{B} < \text{Al} < \text{Ga} < \text{In} < \text{Tl}$. Arrange these elements in increasing order of ionic radii of $\text{M}^{3\oplus}$.

Solution : The given elements are in an increasing order of atomic number. As we go down the group 13, their general outer electronic configuration is ns^2np^1 . $\text{M}^{3\oplus}$ is formed by removal of three electrons from the outermost shell 'n'. In the $\text{M}^{3\oplus}$ the 'n-1' shell becomes the outermost. Size of the added 'n-1' shell increases down the group. Therefore the ionic radii of $\text{M}^{3\oplus}$ also increase down the group as follows :



Problems 9.2 Why the atomic radius of Gallium is less than that of aluminium ?

Solution : Atomic radius increases down the group due to added new shell. 'Al' does not have 'd' electrons. As we go from Al down to 'Ga' the nuclear charge increase by 18 units. Out of the 18 electrons added, 10 electrons are in the inner 3d subshell. 'd' Electrons offer poor shielding effect. Therefore, the effects of attraction due to increased nuclear charge is experienced prominently by the outer electrons of 'Ga' and thus its atomic radius becomes smaller than that of 'Al'.

9.3 Trends in atomic and physical properties of elements of groups 13, 14 and 15. :

The elements of group 13 show a wide variation in properties. In group 13 boron is a metalloid. It is glossy and hard solid like metal but a poor electrical conductor (like nonmetals). The other elements in this group are fairly reactive metals. Aluminium is the third most abundant element in the earth's crust. Some physical and atomic properties of group 13 elements are given in Table 9.2

Table 9.2 : Physical properties of elements of group 13

Element	Atomic number	Atomic mass	Atomic radius (pm)	Ionic radius (pm) $M^{3\oplus}$	Ionization enthalpy (kJ mol ⁻¹)			Electronegativity	Density (g/cm ³)	Melting point (K)	Boiling point (K)
					1 st	2 nd	3 rd				
B	5	10.81	88	27	801	2427	3659	2.0	2.35	24.53	3923
Al	13	26.98	143	53.5	577	1816	2744	1.5	2.70	933	2740
Ga	31	69.72	135	62.0	579	1979	2962	1.6	5.90	303	2676
In	49	114.82	167	80.0	558	1820	2704	1.7	7.31	430	2353
Tl	81	204.38	170	88.5	589	1971	2877	1.8	11.85	576	1730

Problem 9.3 : The values of the first ionization enthalpy of Al, Si and P are 577, 786 and 1012 kJmol⁻¹ respectively. Explain the observed trend.

Solution : The trend shows increasing first ionization enthalpy from Al to Si to P. Al, Si and P belong to 13 period in the periodic table. They have same valence shell. Due to the increased nuclear charge electrons in the valence shell are more tightly held by the nucleus as we go from Al to Si to P. Therefore more energy is required to remove an electron from its outermost shell.

Table 9.3 enlists atomic and physical properties of the elements of carbon family (group 14). In this group all the three traditional types of elements are present. Carbon is a nonmetal, silicon is a metalloid

which is brittle like nonmetal, it is hard and has metallic luster. Germanium is also brittle but hard and lustrous metalloid. Tin or lead down the group are corrosion resistant and moderately reactive.

Table 9.3 : Some atomic and physical properties of group 14 elements

Element	Atomic number	Atomic mass	Atomic radius (pm)	Ionic radius (pm) $M^{3\oplus}$	Ionization enthalpy (kJ mol ⁻¹)				Electro-negativity	Density (g/cm ³)	Melting point (K)	Boiling point (K)
					1 st	2 nd	3 rd	4 th				
C	6	12.01	77		1086	2352	4620	6220	2.5	3.51	4373	
Si	14	28.09	118	40	786	1577	3228	4354	1.8	2.34	1693	3550
Ge	32	72.60	122	53	761	1537	3300	4400	1.8	5.32	1218	3123
Sn	50	118.71	140	69	708	1411	2942	3929	1.8	7.26	505	2896
Pb	82	207.2	146	78	715	1450	3081	4082	1.9	11.34	600	2024

Table 9.4 : Some atomic and physical properties of group 15 elements

Element	Atomic number	Atomic mass	Atomic radius (pm)	Ionic radius (pm)	Ionization enthalpy (kJ mol ⁻¹)			Electronegativity	Density (g/cm ³)	Melting point (K)	Boiling point (K)
					1 st	2 nd	3 rd				
N	7	14.01	70	171 (M ^{3⊕})	1402	2856	4577	3.0	0.879	6.3	77.2
P	15	30.97	110	212 (M ^{3⊕})	1012	1903	2910	2.1	1.823	317	554
As	33	74.92	121	222(M ^{3⊕})	947	1798	2736	2.0	5.778	1089	-
Sb	51	121.75	141	76 (M ^{3⊕})	834	1595	2443	1.9	6.697	904	1860
Bi	83	208.98	148	103(M ^{3⊕})	703	1610	2466	1.9	9.808	544	1837

Group 15 is the nitrogen family. Table 9.4 shows atomic and physical properties of the elements of group 15. This group also include the three traditional types of elements: The gaseous nitrogen and brittle phosphorous are nonmetals. Arsenic and antimony are metalloids while bismuth is moderately reactive metal.

9.4 Chemical properties of the elements of the groups 13,14 and 15

9.4.1 Oxidation state : Oxidation state is the primary chemical property of all elements. The highest oxidation state exhibited by the p-block elements is equal to total number of

valence electrons (sum of s- electrons and p-electrons). This is sometimes called the group oxidation state. In boron, carbon and nitrogen families the group oxidation state is the most stable oxidation state for the lighter elements. Besides, the elements of groups 13, 14 and 15 exhibit other oxidation states which are lower than the group oxidation state by two units. The lower oxidation states become increasingly stable as we move down to heavier elements in the groups. Table 9.5 shows various oxidation states exhibited by elements belonging to these groups.



Remember

The increased stability of the oxidation state lowered by 2 units than the group oxidation state in heavier p-block elements is due to **inert pair effect**. In these elements, the two s-electrons are involved less readily in chemical reactions. This is because the s-electrons of valence shell in p-block elements experience poor shielding than valence p- electron, due to ten inner d-electrons.

Table 9.5 : Oxidation states of the elements of groups 13, 14 and 15

Group	13	14	15
Outer electronic configuration	$ns^2 np^1$	$ns^2 np^2$	$ns^2 np^3$
Group oxidation state	+3	+4	+5
Other oxidation states	+1	+2, -4	+3, -3
Examples of stable compounds	BF ₃ , AlCl ₃ , GaCl ₃ , InCl ₃ , TlBr	CH ₄ , CO ₂ , CCl ₄ , SiCl ₄ , GeCl ₄ , SnCl ₂ , PbCl ₂	N ₂ O ₅ , NH ₃ , NF ₃ , PH ₃ , PCl ₅ , AsH ₃ , SbH ₃ , SbCl ₃ , BiCl ₃

Problem 9.4 : Why Tl^{⊕1} ion is more stable than Tl^{⊕3} ?

Solution : Tl is a heavy element which belongs to group 13 of the p-block. The common oxidation state for this group is 3. In p-block, the lower oxidation state is more stable for heavier elements due to inert pair effect . Therefore, Tl^{⊕1} ion is more stable than Tl^{⊕3} ion.

9.4.2 Bonding in compounds of group 13, 14 and 15 elements :

The lighter elements in groups 13, 14 and 15 have small atomic radii and high ionization enthalpy values. They form covalent bonds with other atoms by overlapping of valence shell orbitals. As we move down the group, the ionization enthalpies are lowered. The atomic radii increase since the valence shell orbitals are more diffused. The heavier elements in these group tend to form ionic bonds. The first member of these groups belongs to second period and do not have d orbitals. B, C and N cannot expand their octet. The subsequent elements in the group possess vacant d orbital in their valence shell, which can expand their octet forming a variety of compounds.

9.4.3 Reactivity towards air/oxygen

a. Group 13 elements : Elements of group 13 on heating with air or oxygen produce oxide of type E_2O_3 (where E = element)

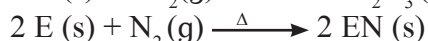
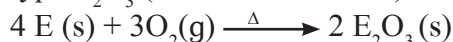

b. Group 14 elements : The elements of group 14 on heating in air or oxygen form oxide of the type EO and EO_2 in accordance with the stable oxidation state and availability of oxygen.

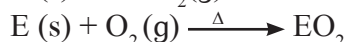

c. Group 15 elements : The elements of group 15 on heating in air or oxygen forms two types of oxide E_2O_3 and E_2O_5 .

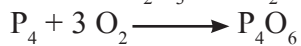

Increase in metallic character down all these groups 13, 14 and 15 reflects their oxides which gradually vary from acidic through amphoteric to basic. (see Table 9.6)

The nature of stable oxides from groups 13, 14 and 15 are given in Table 9.6.

Table 9.6 : Nature of stable oxides of groups 13, 14 and 15 elements

Group	Element	Oxide	Nature
13	B	B_2O_3	Acidic
	Al	Al_2O_3	Amphoteric
	Ga	Ga_2O_3	Amphoteric
	In	In_2O_3	Basic
	Tl	Tl_2O_3	Basic
14	C	CO_2	Acidic
	Si	SiO_2	Acidic
	Ge	GeO_2	Acidic
	Sn	SnO_2	Amphoteric
	Pb	PbO_2	Amphoteric
15	N	N_2O_5	Acidic
	P	P_2O_5	Acidic
	As	As_4O_6	Amphoteric
	Sb	Sb_2O_3	Amphoteric
	Bi	Bi_2O_3	Basic



Do you know ?

Boron nitride is also called inorganic graphite.

9.4.4 Reaction with water

Most of the elements of groups 13,14 and 15 are **unaffected by water**. Aluminium reacts with water on heating and forms hydroxide while tin reacts with steam to form oxide.



Lead is unaffected by water, due to formation of a protective film of oxide.



Do you know ?

Phosphorous is stored under water because it catches fire when exposed to air.

9.4.4 Reaction with halogens

All the elements of **group 13** react directly with halogens to form trihalides (EX_3). Thallium is an exception which forms mono halides (TIX)

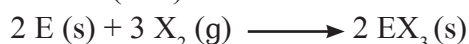

All the elements of **group 14** (except carbon) react directly with halogens to form

tetrahalides (EX_4). The heavy elements Ge and Pb form dihalides as well. Stability of dihalides increases down the group. (Refer to 9.3.1, inert pair effect). The ionic character of halides also increases steadily down the group.

Problem 9.5 : $GeCl_4$ is more stable than $GeCl_2$ while $PbCl_2$ is more stable than $PbCl_4$. Explain.

Solution : Ge and Pb are the 4th and 5th period elements down the group 14. The group oxidation state of group 14 is 4 and the stability of other oxidation state, lower by 2 units, increases down the group due to inert pair effect. The stability of the oxidation state 2 is more in Pb than in Ge.

Elements of the **group 15** reacts with halogens to form two series of halides: EX_3 and EX_5 . The pentahalides possess more covalent character due to availability of vacant d orbitals of the valence shell for bonding. (Nitrogen being second period element, does not have d orbitals in its valence shell, and therefore, does not form pentahalides). Trihalides of the group 15 elements are predominantly covalent except BiF_3 . The only stable halide of nitrogen is NF_3 .

Problem 9.6 : Nitrogen does not form NCl_5 or NF_5 but phosphorous can. Explain.

Solution : Phosphorous and other members of the group can make use of d-orbitals in their bonding and thus compounds MX_3 , as well MX_5 are formed Nitrogen can not form NCl_5 or NF_5 since it is void of d-orbitals in its second shell.

9.5 Catenation : The property of self linking of atoms of an element by covalent bonds to form chains and rings is called catenation. The catenation tendency of an element depends upon the strength of the bond formed.

Among the group 14 elements, carbon shows the maximum tendency for catenation because of the stronger C - C bond (348 kJ mol^{-1})

The order of catenation of group 14 elements is $C \gg Si > Ge = Sn$. Lead does not show catenation. This can be clearly seen from the bond enthalpy values.

Bond	Bond enthalpy (kJmol^{-1})
C - C	348
Si - Si	297
Ge - Ge	260
Sn - Sn	240



Can you recall?

What is common between diamond and graphite?

9.6 Allotropy : When a solid element exists in different crystalline forms with different physical properties such as colour, density, melting point, etc. the phenomenon is called allotropy and individual crystalline forms are called allotropes. Diamond and graphite are well known allotropes of carbon. Fullerenes, graphene and carbon nanotubes are other allotropes of carbon. Elements such as boron, bismuth, silicon, etc. of group 13, 14, and 15 exhibit allotropy. In this chapter we are going to look at some aspects of allotropes of carbon and phosphorous .

9.6.1 Allotropes of Carbon :

a. Diamond : In diamond each carbon atom is linked to four other carbon atoms (via. sp^3 hybrid orbitals) in tetrahedral manner.

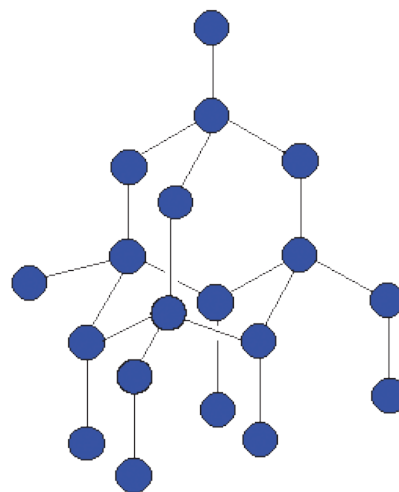

Fig 9.1 Structure of diamond

The C-C bond distance is 154 pm. The tetrahedra are linked together forming a three dimensional network structure (Fig. 9.1) involving strong C-C single bonds. Thus diamond is the hardest natural substance with abnormally high melting point (3930 °C). Diamond is bad conductor of electricity.

Uses : Diamond is used

- for cutting glass and in drilling tools.
- for making dies for drawing thin wire from metal.
- for making jewellery.

b. Graphite : Graphite is composed of layers of two dimensional sheets of carbon atoms (Fig. 9.2) each being made up of hexagonal net of sp^2 carbons bonded to three neighbours forming three sigma bonds. The fourth electron is in the unhybrid p-orbital of each carbon. The p-orbitals on all the carbons are parallel to each other. These overlap laterally to form π bonds. The π electrons are delocalised over the whole layer. The C- C bond length in graphite is 141.5 pm. The individual layers are held by weak van der Waals forces and separated by 335 pm. This makes graphite soft and slippery.

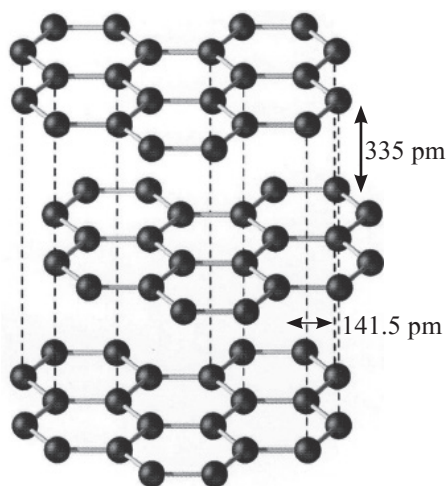

Fig 9.2 Structure of graphite



Remember

Graphite is thermodynamically most stable form (allotrope) of carbon.

c. Fullerene : Fullerenes are allotropes of carbon in which carbon molecules are formed by linking a definite numbers of carbon atoms. For example : C_{60} . Fullerenes are produced,

when an electric arc is struck between the graphite electrodes in an inert atmosphere of argon or helium. The soot formed contains significant amount of C_{60} fullerene and smaller amounts of other fullerenes C_{32} , C_{50} , C_{70} and C_{84} .

C_{60} has a shape like soccer ball and called Buckminsterfullerene or bucky ball. (Fig. 9.3) It contains twenty hexagonal and twelve pentagonal fused rings of carbons.

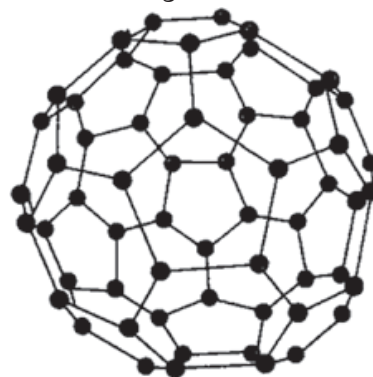

Fig. 9.3 Buckminsterfullerene

Unlike diamond and graphite, the C_{60} fullerene structure exhibits two distinct distances between the neighbouring carbons, 143.5 pm and 138.3 pm. Fullerenes are covalent molecules and soluble in organic solvents. Fullerene C_{60} reacts with group 1 metals forming solids such as K_3C_{60} . The compound K_3C_{60} behaves as a superconductor below 18 K, which means that it conducts electric current with zero resistance.

d. Carbon nanotubes : Carbon nanotubes are cylindrical in shape, consisting of rolled-up graphite sheet (Fig. 9.4). Nanotubes can be single-walled (SWNTs) with a diameter of less than 1 nm or multi-walled (MWNTs) with

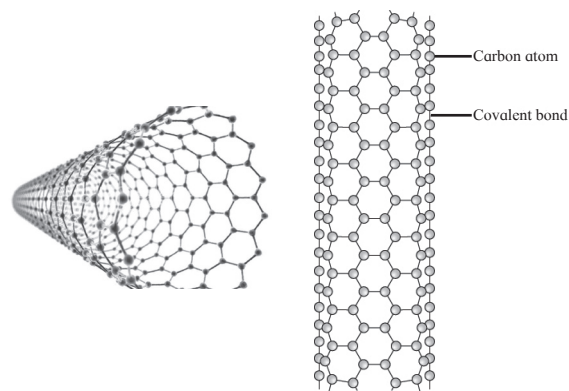

Fig. 9.4 Carbon nanotubes

diameter reaching more than 100 nm. Their lengths range from several micrometres to millimetres.

Carbon nanotubes are robust. They can be bent, and when released, they will spring back to the original shape.

Carbon nanotubes have high electrical and heat conductivities and highest strength to weight ratio for any known material to date. The researchers of NASA are working on combining carbon nanotubes with other materials to obtain composites those can be used to build light weight space craft.

e. Graphene : Isolated layer of graphite is called graphene (Fig. 9.5). Graphene sheet is a two dimensional solid. Graphene has unique electronic properties.

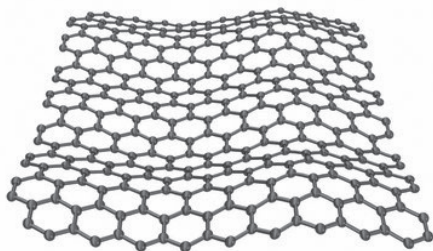

Fig. 9.5 Graphene



Do you know ?

The discovery of graphene was awarded with the Nobel prize to Geim and Novoselov (2010).

9.6.2 Allotropes of phosphorus : Phosphorus is found in different allotropic forms, the important ones being white and red phosphorus.

a. White (yellow) phosphorus : White (yellow) phosphorus consists of discrete tetrahedral P_4 molecules. The P-P-P bond angle is 60° .

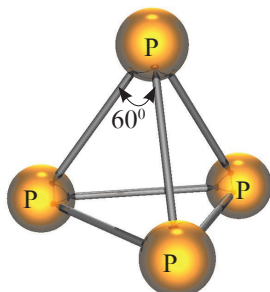

White phosphorus is less stable and hence more reactive, because of angular strain in the P_4 molecule.

- It is translucent white waxy solid.
- It glows in dark (chemiluminescence).
- It is insoluble in water but dissolves in boiling NaOH solution.
- It is poisonous.

b. Red phosphorus : Red phosphorus consists of chains of P_4 tetrahedra linked together by covalent bonds. Thus it is polymeric in nature.

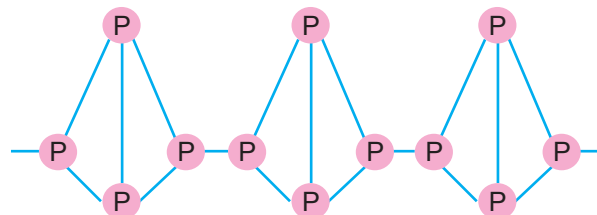

- It is stable and less reactive.
- It is odourless. It possesses iron grey lustre.
- It does not glow in dark.
- It is insoluble in water.
- It is non poisonous.



Remember

Red phosphorus is prepared by heating white phosphorus at 573 K in an inert atmosphere.

9.7 Molecular structures of some important compounds of the group 13, 14 and 15 elements



Can you recall?

- Which element from the following pairs has higher ionization enthalpy? B and Tl, N and Bi
- Does Boron form covalent compounds or ionic ?

You have seen in section 9.2 that lighter elements of groups 13, 14 and 15 have higher ionization enthalpy and because of smaller atomic radius do not form cation readily. These elements form covalent compounds. Covalent molecules have definite shape described with the help of bond lengths and bond angles. Inorganic molecules are often represented by molecular formulae indicating their elemental composition.

In the case of covalent inorganic molecules, the reactivity is better understood from their structures. In this section we will consider molecular structures of common compounds of elements of groups 13,14 and 15.

9.7.1 Boron trichloride (BCl₃) : Boron trichloride (BCl₃) is covalent. Here boron atom is sp² hybridised having one vacant unhybridised p orbital. B in BCl₃ has incomplete octet. The BCl₃ is nonpolar trigonal planar molecule as shown.

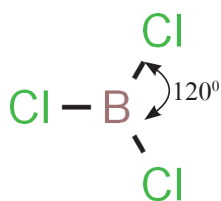

9.7.2 Aluminium Chloride (AlCl₃) :

Aluminium atom in aluminium chloride is sp² hybridised, with one vacant unhybrid p orbital. Aluminium Chloride (AlCl₃) exists as the dimer (Al₂Cl₆) formed by overlap of vacant 3d orbital of Al with a lone pair of electrons of Cl.

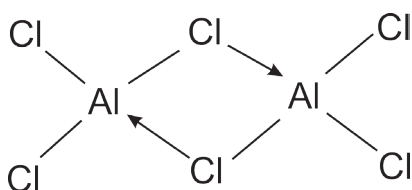

9.7.3 Orthoboric acid / boric acid (H₃BO₃) :

The orthoboric acid has central boron atom bound to three -OH groups. The solid orthoboric acid has layered crystal structure in which trigonal planar B(OH)₃ units are joined together by hydrogen bonds.

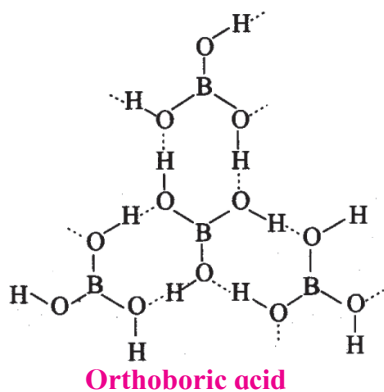

9.7.4 Diborane (B₂H₆) : Boron has only three valence electron. In diborane each boron atom is sp³ hybridized. Three of such hybrid orbitals are half filled, the fourth sp³ hybrid orbital is vacant.

The two half filled sp³ hybrid orbitals of each B atom overlap with 1s orbitals of two H atoms and form four B-H covalent bonds. Hydrogen atoms are located at the terminal. Besides, there are **2-centre - 2-electron** bonds where '1s' orbital of each of the remaining two H atoms simultaneously overlap with half filled hybrid orbital of one B atom and the vacant hybrid orbital of the other B atom. This type of overlap produces two three centred - two electron bonds (3 c - 2 e) or banana bonds. Hydrogen atoms involved in (3 c - 2 e) bonds are the bridging H- atoms. In diborane two B atoms and four terminal H atoms lie in one plane, while the two bridging H atoms lie symmetrically above and below this plane.

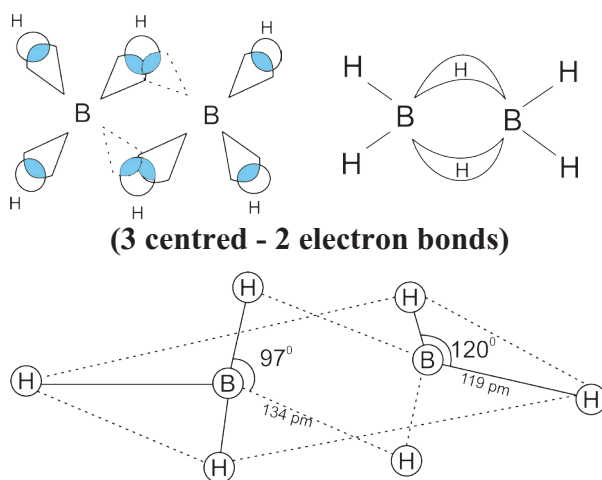

Bonding and structure of diborane

9.7.5 Silicon dioxide (SiO₂) : Silicon dioxide is commonly known as silica. Quartz, cristobalite and tridymite are different crystalline forms of silica. They are inter-convertible at a suitable temperature.

Silicon dioxide (silica) is a covalent three dimensional network solid, in which each silicon atom is covalently bound in tetrahedral manner to four oxygen atoms. The crystal contains eight membered rings having alternate silicon and oxygen atoms.

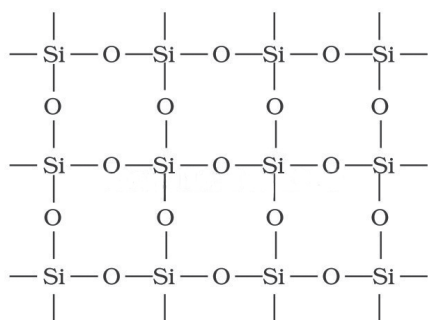

Structure of SiO_2

9.7.6 Nitric acid (HNO_3) : Nitric acid is a strong, oxidising mineral acid. The central nitrogen atom is sp^2 hybridised. HNO_3 exhibits resonance phenomenon.

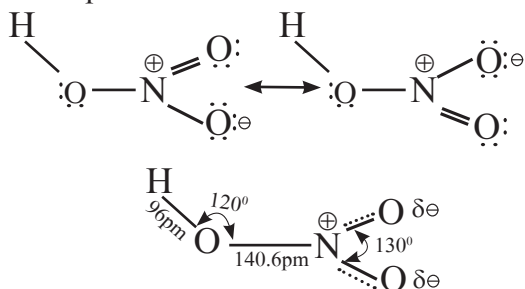

Resonance Hybrid of HNO_3

9.6.7 Orthophosphoric acid/phosphoric acid (H_3PO_4) : Phosphorus forms number of oxyacids. Orthophosphoric acid is a strong non toxic mineral acid. It contains three ionizable acidic hydrogens. The central phosphorous atom is tetrahedral.

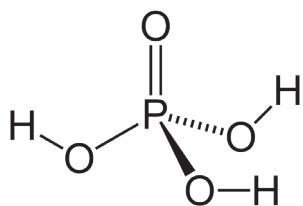

Try this

Find out the structural formulae of various oxyacids of phosphorus.

9.8 Chemistry of notable compounds of elements of groups 13, 14 and 15

9.8.1 Borax ($\text{Na}_2\text{B}_4\text{O}_7$) : It is one of the most important boron compound. The crystalline borax has formula $\text{Na}_2\text{B}_4\text{O}_7 \cdot 10\text{H}_2\text{O}$ or $\text{Na}_2[\text{B}_4\text{O}_5(\text{OH})_4] \cdot 8\text{H}_2\text{O}$.

Borax naturally occurs as tincal (which contains about 90% borax) in certain inland lakes in India, Tibet and California (U.S.A).

Preparation :

Borax is prepared from the mineral colemanite by boiling it with a solution of sodium carbonate.

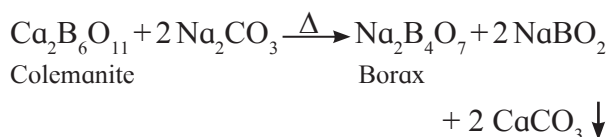

Properties

- Borax is white crystalline solid.
- Borax dissolves in water and gives alkaline solution due to its hydrolysis.

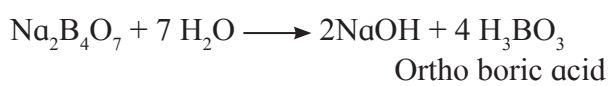

- On heating borax first loses water molecules and swells. On further heating it turns into a transparent liquid, which solidifies into glass like material known as borax bead.

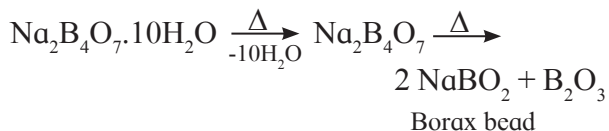

The borax bead consisting sodium metaborate and boric anhydride is used to detect coloured transition metal ions, under the name borax bead test. For example, when borax is heated in a Bunsen burner flame with CoO on a loop of platinum wire, a blue coloured $\text{Co}(\text{BO}_2)_2$ bead is formed.

- Borax when heated with ethyl alcohol and concentrated H_2SO_4 acid, give volatile vapours of triethyl borate which burn with green edged flame.

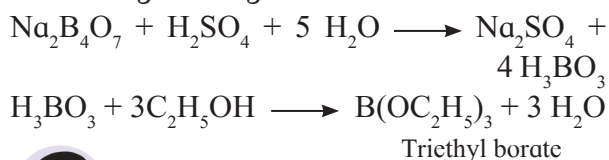

Remember

The above reaction is used as a test for detection and removal of borate in qualitative analysis.

Uses : Borax is used

- in the manufacture of optical and hard borosilicate glass.
- as a flux for soldering and welding.
- as a mild antiseptic in the preparation of medical soaps
- in quantitative analysis for borax bead test.
- as a brightener in washing powder.

9.8.2 Silicones : Silicones represent organo-silicon polymers where $\{R_2SiO\}$ is a repeating unit. These are held together by $-\overset{|}{Si}-O-\overset{|}{Si}-$ linkage. Silicones have empirical formula R_2SiO ($R = CH_3$ or C_6H_5 group). This is similar to that of ketone (R_2CO) and hence the name silicones.

Preparation : The starting materials for manufacture of silicones are alkyl or aryl substituted silicon chlorides, $R_nSiCl_{(4-n)}$ where R is alkyl or aryl group.

When methyl chloride reacts with silicon in the presence of copper catalyst at a temperature 573 K, various types of methyl substituted chlorosilane of formulae $MeSiCl_3$, Me_2SiCl_2 , Me_3SiCl with small amounts of Me_4Si are formed.

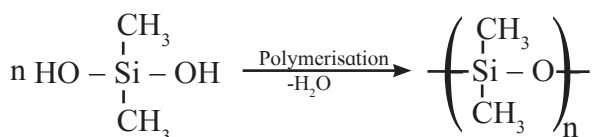
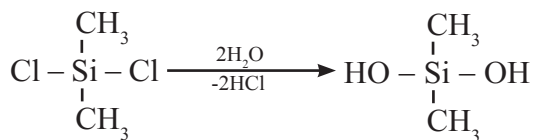
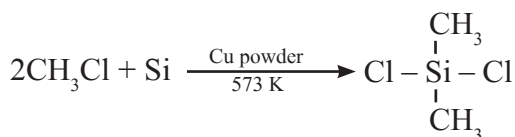

Hydrolysis of dimethyl dichlorosilane, $(CH_3)_2SiCl_2$ followed by condensation polymerisation yields straight chain silicone polymers.

The chain length of polymer can be controlled by adding $(CH_3)_3SiCl$ at the end as shown :

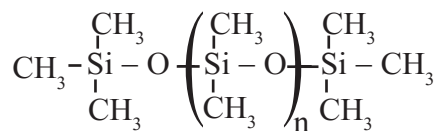

Properties of silicones

- They are water repellent.
- They have high thermal stability.
- They are good electrical insulators.
- They are resistant to oxidation and chemicals.

Uses of silicones

They are used as

- insulating material for electrical appliances
- water proofing of fabrics
- sealant
- high temperature lubricants
- For mixing in paints and enamels to make them resistant to high temperature, sunlight and chemicals.

9.8.3 Ammonia (NH_3)

Preparation

- Ammonia is present in small quantities in air and soil where it is formed by the decomposition of nitrogenous organic matter such as urea.

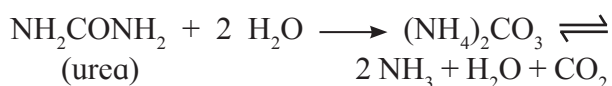

- Ammonia is prepared on laboratory scale, by decomposition of the ammonium salts with calcium hydroxide or caustic soda.

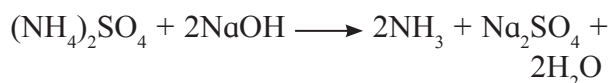
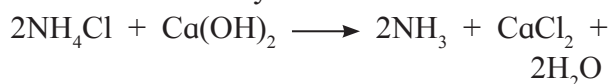

- On the large scale ammonia is prepared by direct combination of dinitrogen and dihydrogen. (Haber's process)



High pressure favours the formation of ammonia. The optimum conditions for the production of ammonia are high pressure of 200×10^5 Pa (200 atm), temperature of ~ 700 K and use of a catalyst such as iron oxide with trace amounts of K_2O and Al_2O_3 . Under these conditions equilibrium attains rapidly.

Properties

a. Physical properties

- Ammonia is colourless gas with pungent odour.
- It has freezing point of 198.4 K and boiling point of 239.7 K.
- It is highly soluble in water. The concentrated aqueous solution of NH_3 is called liquor ammonia.



Remember

Ammonia has higher melting point and boiling point, because in the solid and liquid state NH_3 molecules get associated together through hydrogen bonding. Thus some more energy is required to break such intermolecular hydrogen bonds.

b. Chemical properties

i. Basic nature : The aqueous solution of ammonia is basic in nature due to the formation of OH^- ions.

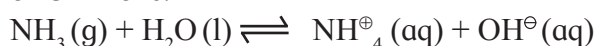

ii. Ammonia reacts with acids to form ammonium salts.

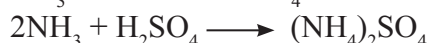
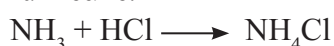

iii. Aqueous solution of ammonia precipitates out as hydroxides (or hydrated oxides) of metals from their salt solutions.

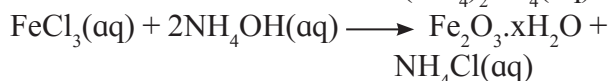
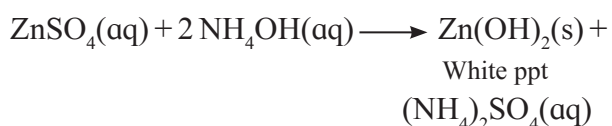

iv. Complex formation :

The lone pair of electrons on nitrogen the atom facilitates complexation of ammonia with transition metal ions.

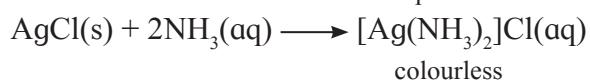
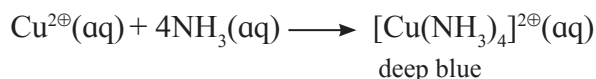

Remember

This reaction is used for the detection of metal ions such as Cu^{2+} , Ag^+ .

Uses

Ammonia is used in

- manufacture of fertilizers such as urea, diammonium phosphate, ammonium nitrate, ammonium sulphate etc.
- manufacture of some inorganic compounds like nitric acid.
- refrigerant (liq. ammonia).
- laboratory reagent in qualitative and quantitative analysis (aq. solution of ammonia)



Remember

Ammonia gives brown ppt with Nessler's reagent (alkaline solution of K_2HgI_4).

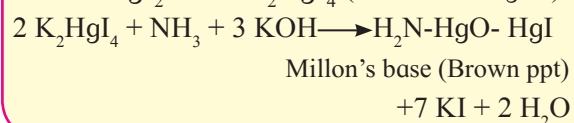
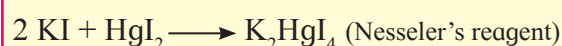
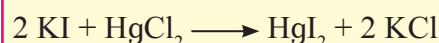



Exercises

1. Choose correct option.

- A. Which of the following is not an allotrope of carbon ?
a. bucky ball b. diamond
c. graphite d. emerald
- B. is inorganic graphite
a. borax b. diborane
c. boron nitride d. colemanite
- C. Haber's process is used for preparation of.....
a. HNO_3 b. NH_3
c. NH_2CONH_2 d. NH_4OH
- D. Thallium shows different oxidation state because
a. of inert pair effect
b. it is inner transition element
c. it is metal
d. of its high electronegativity
- E. Which of the following shows most prominent inert pair effect ?
a. C b. Si
c. Ge d. Pb

2. Identify the group 14 element that best fits each of the following description.

- A. Non metallic element
B. Form the most acidic oxide
C. They prefer +2 oxidation state.
D. Forms strong π bonds.
3. Give reasons.
A. $\text{Ga}^{3\oplus}$ salts are better reducing agent while $\text{Tl}^{3\oplus}$ salts are better oxidising agent.
B. PbCl_4 is less stable than PbCl_2
4. Give the formula of a compound in which carbon exhibit an oxidation state of
A. +4 B. +2 C. -4
5. Explain the trend of the following in group 13 elements :
A. atomic radii B. ionization enthalpy
C. electron affinity
6. Answer the following
A. What is hybridization of Al in AlCl_3 ?
B. Name a molecule having banana bond.
7. Draw the structure of the following
A. Orthophosphoric acid
B. Resonance structure of nitric acid

8. Find out the difference between

- A. Diamond and Graphite
B. White phosphorus and Red phosphorus
9. What are silicones? Where are they used?
10. Explain the trend in oxidation state of elements from nitrogen to bismuth.
11. Give the test that is used to detect borate radical is qualitative analysis.
12. Explain structure and bonding of diborane.
13. A compound is prepared from the mineral colemanite by boiling it with a solution of sodium carbonate. It is white crystalline solid and used for inorganic qualitative analysis.
a. Name the compound produced.
b. Write the reaction that explains its formation.

14. Ammonia is a good complexing agent. Explain.

15. State true or false. Correct the false statement.

- A. The acidic nature of oxides of group 13 increases down the graph.
B. The tendency for catenation is much higher for C than for Si.

16. Match the pairs from column A and B.

A	B
BCl_3	Angular molecule
SiO_2	linear covalent molecule
CO_2	Tetrahedral molecule
	Planar trigonal molecule

17. Give the reactions supporting basic nature of ammonia.

18. Shravani was performing inorganic qualitative analysis of a salt. To an aqueous solution of that salt, she added silver nitrate. When a white precipitate was formed. On adding ammonium hydroxide to this, she obtained a clear solution. Comment on her observations and write the chemical reactions involved.



Activity :

Prepare models of allotropes of carbon and phosphorous.