

## 4. Effects of electric current



- Energy transfer in electric circuit.
- Heating effects of electric current.
- Magnetic effects of electric current.



**Can you recall?**

1. How do we decide that a given material is a good conductor of electricity or is an insulator?
2. Iron is a conductor of electricity, but when we pick up a piece of iron resting on the ground, why don't we get electric shock?

We have learnt in earlier standards about static electricity. We performed various experiments regarding negatively and positively charged objects. The reason behind the object becoming positively and negatively charged is the transfer of negatively charged particles from one object to another object. In previous standard, we also studied about electric current.

In this chapter, we will study about an electric current flowing through a conducting wire, an electric current flowing through a resistor, electromagnetic induction, electric motor and generator.



**Observe and Discuss**

What do you observe in the following pictures?  
Which effects of electric current do you find?

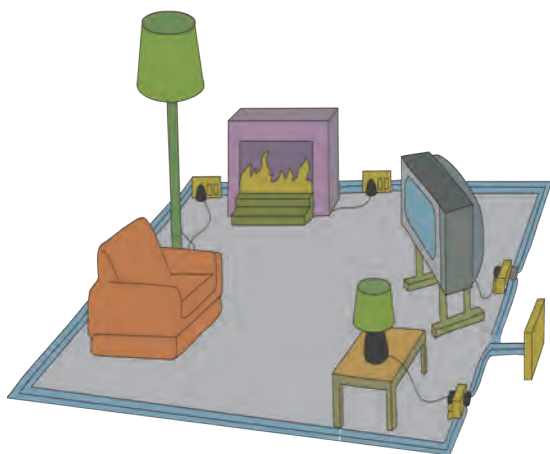

a

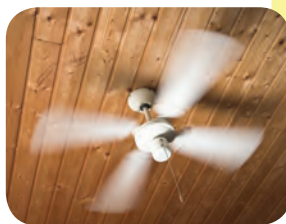

b

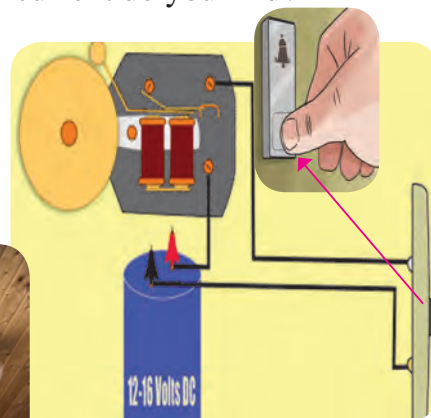

c

### 4.1 Effects of electric current

#### Energy transfer in an electric circuit



**Try this**

**Materials:** connecting wires, electric cells, electrical resistance, voltmeter, ammeter, plug key.

**Procedure:** Connect the circuit as shown in the accompanying figure 4.2 after taking the components with proper values. Measure the current ( $I$ ). Also measure the potential difference ( $V_{AB}$ ) between the two ends (A and B) of the resistance.

The potential at A is higher than the potential at B as the point A is connected to the positive electrode of the cell and the point B to the negative electrode of the cell.

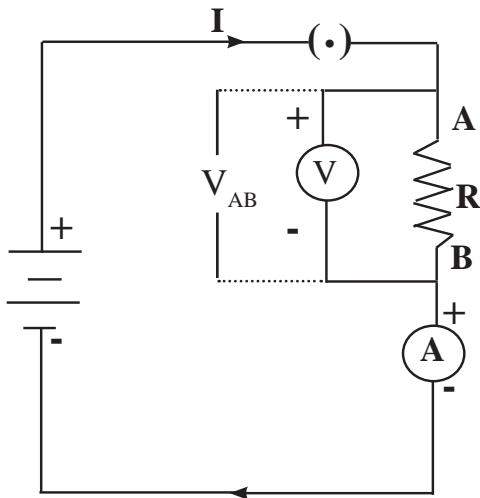

**4.2 Electric circuit**

If a charge  $Q$  flows from A to B, work  $V_{AB} Q$ , has been done on  $Q$  while going from A to B (Refer to chapter 3 of std 9). From where does the energy come to do this work? The source of energy is the cell. The cell gives this energy through the charge  $Q$  to the resistance where work  $V_{AB} Q$  is performed. If the charge  $Q$  flows from A to B in time  $t$ , i.e. the work is performed in time  $t$ , then during that time the energy  $V_{AB} Q$  is given to the resistor.

What happens to this energy? This energy is received by the resistor and is converted into heat energy, the temperature of the resistor is increased.



**Use your brain power !**

If in the circuit, the resistor is replaced by a motor, in which form will the energy given by the cell get transformed into?

$$P = \text{Electrical power} = \frac{\text{Energy}}{\text{Time required}} = \frac{V_{AB} Q}{t} = V_{AB} I \dots\dots\dots(1) \quad \because \quad \frac{Q}{t} = I ,$$

The source of energy, the cell, gives in time  $t$ , the energy  $P \times t$  to the resistor. If  $I$  is the current flowing continuously through the circuit, the heat produced in the resistor in time  $t$  will be

$$H = P \times t = V_{AB} \times I \times t \dots\dots\dots (2)$$

According to Ohm's law,

$$V_{AB} = I \times R \dots\dots\dots (3)$$

$$H = V_{AB}^2 \times \frac{t}{R} \dots\dots\dots (4)$$

$$\text{Similarly, } H = I \times I \times R \times t = I^2 \times R t \dots\dots\dots (5)$$

$H = I^2 \times R \times t$  is called Joules law of heating

**Unit of electrical power**

$$P = V_{AB} \times I = \text{Volt} \times \text{Amp} \dots\dots\dots (6)$$

$$1 \text{ Volt} \times 1 \text{ Amp} = \frac{1\text{J}}{1\text{C}} \times \frac{1\text{C}}{1\text{s}} \dots\dots\dots (7)$$

$$\frac{1\text{J}}{1\text{s}} = \text{W (watt)} \dots\dots\dots (8)$$

Thus the unit of electrical power is 1W (watt).



**Think about it**

How can we write mechanical power in a manner similar to the electrical power?

**Heating effect of electric current**

When a resistor is connected in an electrical circuit, heat is produced in it due to the current. This is known as the heating effect of current.



Coiled coil



Coil (Solenoid type)



Coil of cooker

Coil of Heater

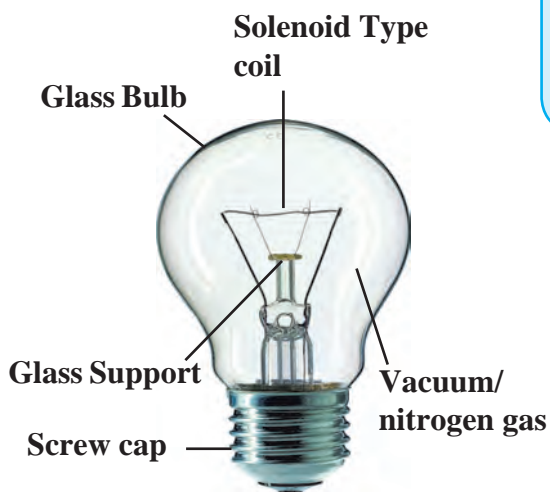

### 4.3 Uses of coil



#### Find out

Check monthly electricity bill received from the electricity distribution Co. Ltd. Observe various details and get information about them. The electricity bill specifies the usage in 'Units'. What is this unit? When 1 kWh electrical energy is used, it is termed as 1 unit of energy.

Equipment such as water boiler, electric cooker, electric bulb make use of the heating effect of electric current. Electrical conductors having higher resistivity are used here. For example, a coil made up of an alloy Nichrome is used in the electric heater-cooker as a resistor, while a tungsten wire is used in an electric bulb. Because of the current, this wire gets heated (to nearly 3400 °C) and emits light. The hot wire also radiates heat to a certain extent.



#### Always remember

The unit of electric power 1W is a very small unit, hence 1000 W or 1 kW is used as a unit to measure electric power, in practice. If 1 kW power is used for 1 hour, it will mean  $1\text{ kW} \times 1\text{ hr}$  of electrical energy is used (see equation 1)  
 $1\text{ kWh} = 1\text{ kilowatt hour} = 1000\text{ W} \times 3600\text{ s}$   
 $= 3.6 \times 10^6\text{ Ws} = 3.6 \times 10^6\text{ J}$

Several times we hear or read about a building catching fire due to short circuit. Sometimes, if we switch on an equipment in our house, the electrical fuse wire melts and the electric supply shuts down. Let us discuss about the cause briefly. The home electrical connection consists of 'live', 'neutral' and 'earth' wires. The 'live' and the 'neutral' wires have potential difference of 220V. The 'earth' is connected to ground. Due to a fault in the equipment or if the plastic coating on the 'live' and the 'neutral' wires gives way, the two wires come in contact with each other and a large current flows through it producing heat. If any inflammable material (such as wood, cloth, plastic etc.) exists around that place it can catch fire. Therefore, a fuse wire is used as a precautionary measure. We have learnt about fuse wire in the previous standard. As soon as high current flows in a circuit, the fuse wire melts and breaks the circuit and any mishap is avoided.

Many times particularly in the summer season, huge electrical power is used in the evenings due to home lighting, fans, air conditioners, use of electricity in shops etc. As a result, excessive current is drawn from the transformer supplying the electricity, and if the capacity of the transformer is insufficient, its fuse wire melts and the supply gets shut down. Such events occur due to overloading.



**4.4 Different types of fuses in use**



**Do you know ?**

These days miniature circuit breakers (MCB) switches are used in homes. When the current in the circuit suddenly increases this switch opens and current stops. Different types of MCBs are in use. For the entire house, however the usual fuse wire is used.



**Solved examples**

**Example 1.** A 6 m long wire made from an alloy, nichrome, is shaped into a coil and given for producing heat. It has a resistance of 22 ohms. Can we get more heat if the wire is cut into half of its original length and shaped into a coil? For getting energy, the two ends of the wire are connected to a source with a potential difference of 220V.

**Given :** Resistance 22 ohm, potential difference = 220 V

A. Coil of whole wire.

$$P = \frac{V^2}{R} = \frac{(220)^2}{22} = 2200 \text{ watts}$$

B. Coil of half-length wire

$$P = \frac{V^2}{R} = \frac{(220)^2}{11} = 4400 \text{ watts}$$

This means that more heat will be obtained after cutting the wire into half.

**Example 2.** A cell is connected to a 9 ohm resistance, because of which heat of 400 J is produced per second due to current flowing through it. Obtain the potential difference applied across the resistance.

**Given:**

Heat at 400 J per second means

$$P = \frac{400 \text{ J}}{1 \text{ s}}$$

$$P = \frac{V^2}{R}$$

$$400 = \frac{V^2}{9}$$

$$400 \times 9 = V^2$$

$$\therefore V = \sqrt{(400 \times 9)} = 20 \times 3 = 60 \text{ V}$$

**Example 3.** An electrical iron uses a power of 1100 W when set to higher temperature. If set to lower temperature, it uses 330 W power. Find out the electric current and the respective resistances for the two settings. The iron is connected to a potential difference of 220 V.

Given: potential difference = 220 V.

Power P = (A) 1100 W, (B) = 330 W.

A. Power = 1100 W.

$$I_1 = \frac{P}{V} = \frac{1100}{220} = 5 \text{ A}$$

B. Power = 330 W

$$I_2 = \frac{P}{V} = \frac{330}{220} = 1.5 \text{ A}$$

$$\text{Resistance } R_1 = \frac{V}{I_1} = \frac{220}{5} = 44 \Omega$$

$$\text{Resistance } R_2 = \frac{V}{I_2} = \frac{220}{1.5} = 146 \Omega$$

**Example 4.** An electric tungsten bulb is connected into a home circuit. The home electric supply runs at 220 V potential difference. When switched on, a current of 0.45 A flows through the bulb. What must be power (wattage) of the bulb? If it is kept on for 10 hours, how many units of electricity will be consumed?

**Given :** Potential difference = 220 V.

Current = 0.45 A.

$$\begin{aligned} \text{Power (W)} &= \text{Potential difference(V)} \\ &\quad \times \text{Current (A)} \\ &= 220 \times 0.45 \text{ W} \\ &= 99 \text{ W.} \end{aligned}$$

The bulb must be of power 99 W.

In 10 hrs,

$$\begin{aligned} 99 \text{ W} \times 10 \text{ h} &= 990 \text{ Wh.} \\ &= 0.99 \text{ kWh.} \end{aligned}$$

### Magnetic effect of electric current

We have learnt about heating effect of electric current. In previous standards, we have studied about magnets and magnetic lines of force. However, it will be interesting to see if an electric current and magnetic field are related to each other.



#### Try this

Connect the circuit as shown in figure 4.5. Connect a copper wire, thicker and straight as compared to the connecting wires, between A and B. Keep a magnetic needle adjacent to the wire. Keep the plug key open in the circuit and observe the direction of the needle. Close the plug key and observe the direction of the needle. What do you notice? Now interchange the connecting wires connected to the cell and observe the direction of the magnetic needle. Do you notice any relation between the direction of current and position of the needle?

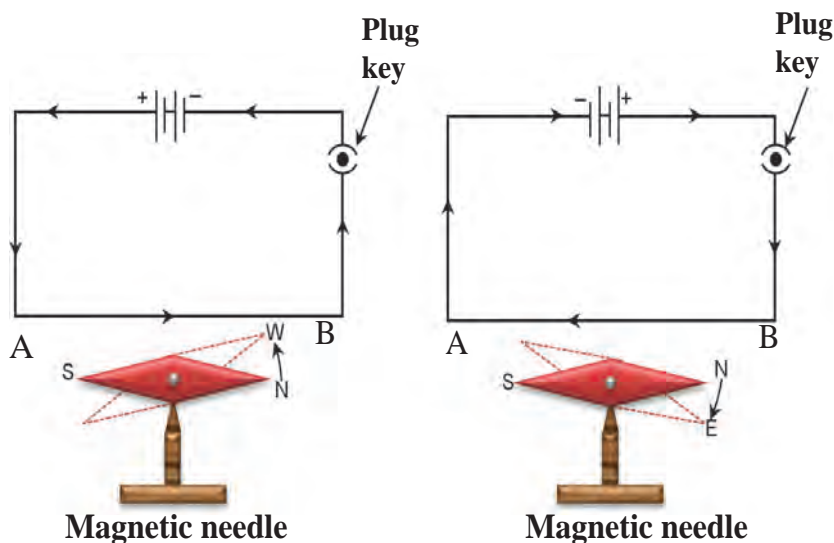

### 4.5 Magnetic effects of a current

What do you learn from this experiment? The magnetic effect is observed because of the current in the wire. This means electricity and magnetism are closely related! On the contrary, if a magnet is moved and kept moving, will we observe any electric effect? Is it not exciting? Therefore, we are going to study magnetic fields and such 'electromagnetic' effects. Finally, we will study the principles, construction and working of electric motor and electric generator.

### Introduction of Scientist



**Hans Christian Oersted (1777-1851)**

As a scientist at the forefront in the 19th century, Hans Christian Oersted played an important role in understanding 'electromagnetism'. He observed, in 1820, that when a current passes through a metal wire, the magnetic needle near the wire turns through a certain angle. He pointed out the relation between electricity and magnetism. Today's advanced technology is developed as a consequence. In his honour, the unit of intensity of the magnetic field is termed as Oersted.



### Try this

Connect the circuit as shown in fig. 4.6 When a large current (approximately 1A or more) flows through the thick copper wire passing through a cardboard, the magnetic needle kept at different points on the cardboard around the wire stands in different directions. Mark these directions with a pencil.

(Discuss with your friends and teachers about the requirement of the current, number of cells, cells of what potential difference, thickness of the wire etc., and then perform the experiment). The direction of the current shown in the circuit is its conventional direction.

What changes are caused by increasing or decreasing current? What do you see when the magnetic needle is kept a little away from the wire? Now, instead of the magnetic needle, spread iron filings on the cardboard and observe. The iron filings arrange themselves in a circular manner around the wire. Why does this happen?

You have studied magnetism and magnetic field in previous standard. The iron filings spread along the magnetic lines of force.

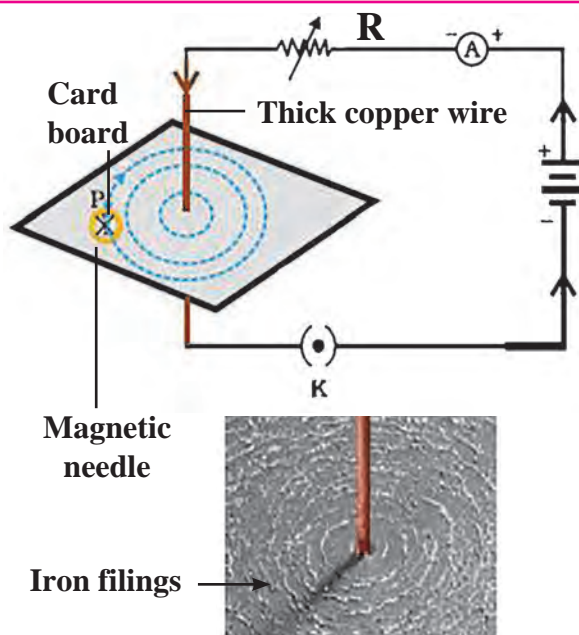

**4.6 Magnetic field produced around the conductor**



### Always remember

A magnetic field is produced around a straight current carrying conductor. If the current is unchanged, this magnetic field reduces as the distance from the wire increases. Therefore, the concentric circles representing the magnetic lines of force are shown bigger and rarefied as the distance from the wire increases. If the current through the wire is increased, the intensity of the magnetic field increases.

## Right hand thumb Rule

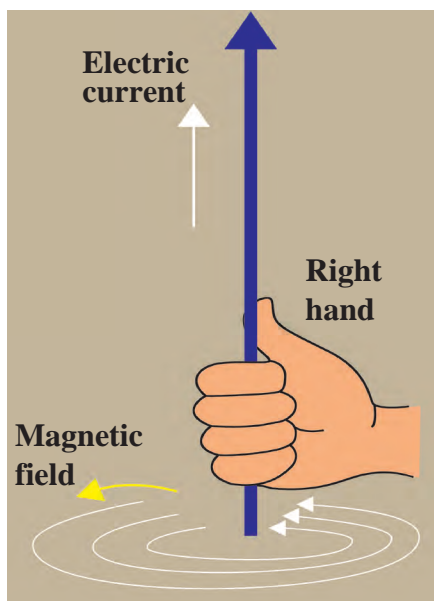

4.7 Right hand thumb Rule

This is a convenient rule for finding out the direction of the magnetic field produced by a current flowing through an electrical conductor. Imagine that you have held the conductor in your right hand in such a way that your thumb points in the direction of the current. Then turn your fingers around the conductor, the direction of the fingers is the direction of the magnetic lines of force (Fig. 4.7).



The right hand thumb rule is called Maxwell's cork-screw rule. What is the cork-screw rule?

## Magnetic field produced by current through a circular loop of a conducting wire.

We learnt about the magnetic lines of force of a magnetic field produced by a current flowing through a straight conductor. What will happen to the magnetic lines of force of the field produced by a current flowing through a loop made by bending the straight wire?

A circuit is completed by connecting various components as shown in the figure 4.8. If the current passes through the loop, magnetic lines of force are produced at each point on the loop. As we go away from the wire, the concentric circles representing the magnetic lines of force will become bigger and bigger.

As we go towards the centre of the loop the circle become so big that its arc can be shown as a straight line.

In fig. 4.8, the magnetic lines of force are shown near the points P and Q only, however, they will be created near each point on the loop. Likewise, each point will produce magnetic field at the centre of the loop.

By making use of the right hand thumb rule, check that every point on the loop contributes the magnetic lines of force at the centre of the loop and these lines of force at the centre of the loop are in the same direction.

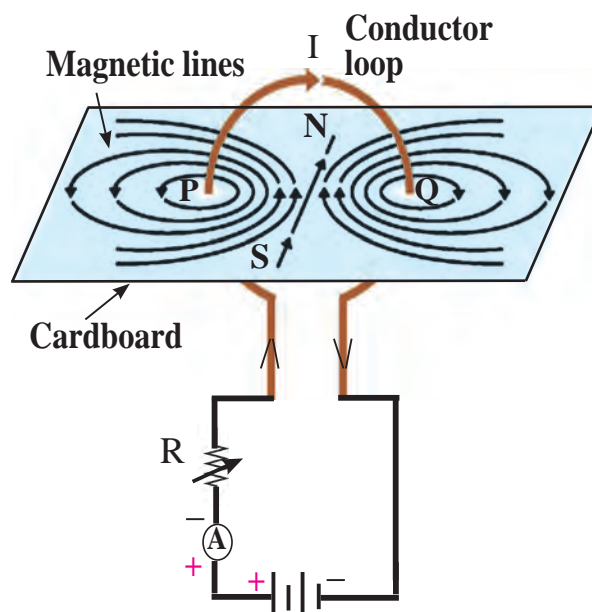

4.8 Magnetic field produced by a current through a loop of conducting wire

The intensity of magnetic field at any point produced by a current flowing through a wire, is dependent on the current, as we have seen in the experiment (fig 4.6 Try this). This means that if there are  $n$  turns in the loop, the magnetic field  $n$  times of that produced by a single loop will be created.

On discussing with your teachers, with their guidance, see if you can perform the above experiment by collecting appropriate materials. The direction of the magnetic field can be determined with the help of a magnetic needle.

### Magnetic field due to a current in a solenoid.

When a copper wire with a resistive coating is wound in a chain of loops (like a spring), it is called solenoid.

Whenever an electric current passes through a solenoid, magnetic lines of force are produced in a pattern as shown in figure 4.9.

You are aware of the magnetic lines of force of a bar magnet. The properties of the magnetic field of a solenoid are very similar to the magnetic field produced by a bar magnet.

One of the open ends of a solenoid acts as a magnetic north pole and the other as the magnetic south pole. The magnetic lines of force inside the solenoid are parallel to each other. What does this mean?

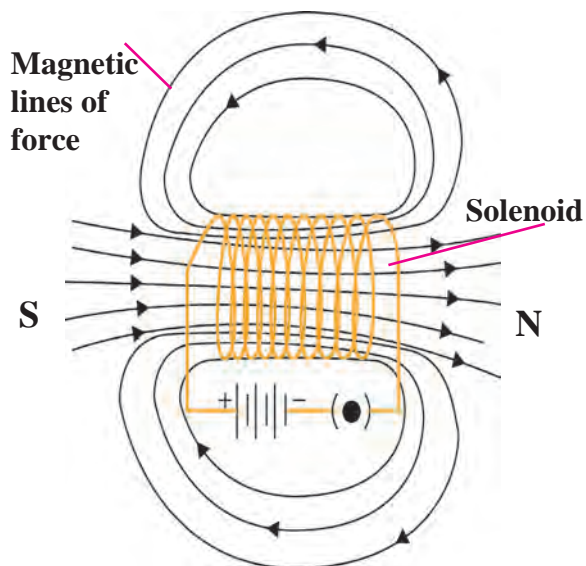

4.9 Magnetic lines of force of a magnetic field produced by a current passing through a solenoid coil.

This means that the intensity of the magnetic field within the solenoid is uniform everywhere, i.e. the magnetic field in a solenoid is uniform.

### Force acting on current carrying conductor in a magnetic field



#### Try this

**Materials:** Flexible copper wire, stand, electric cell, a horse shoe magnet with a strong magnetic field.

**Procedure :** Using the stand, fix the copper wire so that it passes through the poles of the horse shoe magnet as shown in the figure 4.10. Connect the circuit as well. What do you observe?

Whenever a current is not flowing through the wire, it remains straight (position A). When the current flows from top to bottom, the wire bends and comes into position C.

If the current direction is reversed, i.e. it flows from the bottom to the top end, the wire bends but comes in the position B. This means the direction of the force on the wire is perpendicular to both the magnetic field and the direction of the current.

Here, the direction of magnetic field is from N to S, (H). In this experiment it is noted that whenever current flows through a conductor in the presence of magnetic field a force is exerted on the conductor. If the direction of the current is reversed, the direction of the force also gets reversed. If the magnet is kept reversed, i.e. its south pole is brought at the position of its North pole and its North pole brought to the position of its south pole, what will happen?



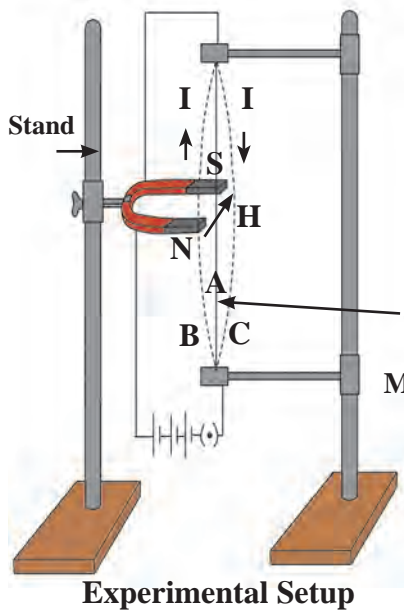

The above experiment clearly shows that a force is exerted on the current carrying conductor. The direction of this force depends on both the direction of the current and the direction of the magnetic field.

Experimentally, it is possible to show that this force is maximum when the direction of the current is perpendicular to the direction of the magnetic field. How will you do this?

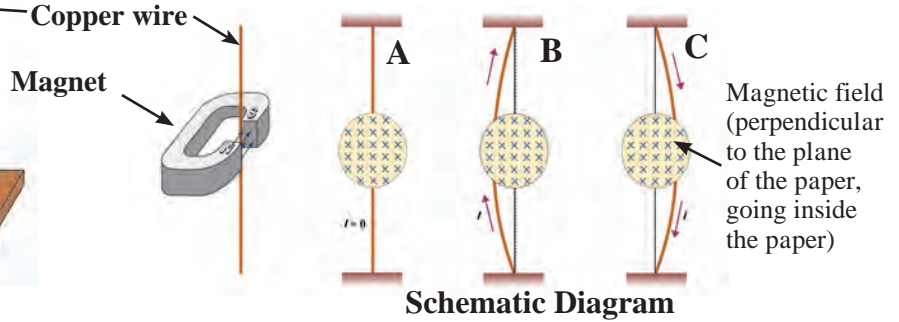

#### 4.10 Force acting on a current carrying conductor in the presence of a magnetic field

##### Fleming's left hand rule

In the above experiment we considered the direction of the electric current and the direction of the magnetic field and found that the direction of the force exerted is perpendicular to both. There is a simple rule relating these three directions. This rule is called Fleming's left hand rule. According to this rule, the left hand thumb, index finger, and the middle finger are stretched so as to be perpendicular to each other. If the index finger is in the direction of the magnetic field, and the middle finger points in the direction of the current, then the direction of the thumb is the direction of the force on the conductor.

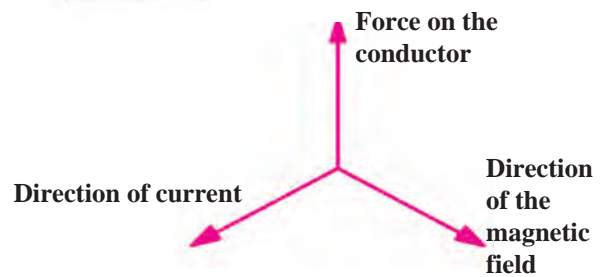
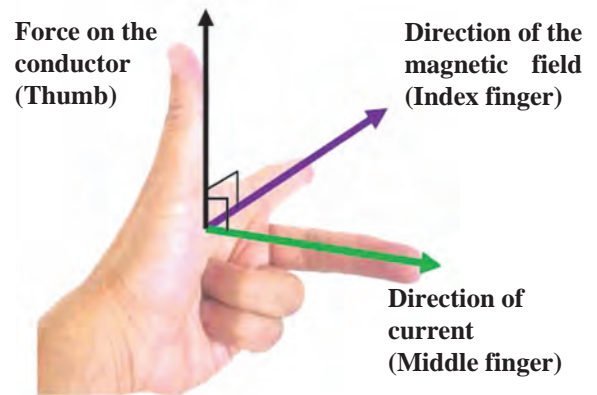

**Try this.**

Determine the direction of the force on the wire in the above experiment and verify your finding.

#### 4.11 Fleming's left hand rule

##### Electric Motor

You know various forms of energy. You also know that energy can change its form. A device changing electrical energy into mechanical energy is known as electric motor. Around us, in our day-to day life, an electric motor is a boon. It is used in fans, refrigerators, mixers, washing machines, computers, pumps, etc. How does this motor work?



#### 4.12 Electric motor in daily use

The electric motor consists of rectangular loop of copper wire having resistive coating. As shown in the figure, it is placed between the north pole and south pole of a magnet (such as a horse shoe magnet) in such a way that its branches AB and CD are perpendicular to the direction of magnetic field. The two ends of the loop are connected to the two halves (X and Y) of the split ring. The two halves of the ring have resistive coating on their inner surfaces and are tightly fitted on the axle. The two halves of the split ring, X and Y, have their outer conducting surfaces in contact with the two stationary carbon brushes, (E and F), respectively.

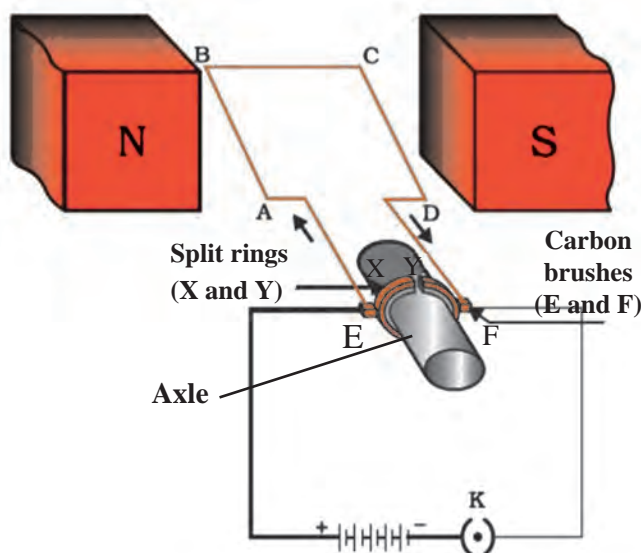

**4.13 Electric motor: Principle and Working**

When the circuit is completed as shown in the figure, the current flows in the branch AB of the loop from A to B through the carbon brushes E and F. Since the direction of the magnetic field is from north pole to south pole, according to the Fleming's left hand rule, a force is exerted on the branch AB and pushes it down. The current in the CD branch is in a opposite direction to that in the AB branch, and therefore, a force is exerted on the branch CD in upward direction. Thus, the loop and the axle start rotating in an anticlockwise direction. After half rotation, the two halves of the split ring X and Y come in contact with carbon brushes F and E, respectively, and the current in a loop starts flowing in the direction DCBA. Therefore, a force is exerted on the branch DC in downward direction and on the branch BA in the upward direction, and the loop continues to rotate in the anticlockwise direction. Thus, the current in the loop is reversed after each half rotation and the loop and the axle continue to rotate in the anticlockwise direction.

Commercial motors run on the same principle, but practical changes are made in their construction; you will learn that later.



**Find Out**

Why are carbon brushes used? How do these work? In order to find answers to such questions, visit a nearby workshop and try to understand the construction of an electric motor.

**Electromagnetic Induction**

We have seen in the previous section that if we keep an electric conductor in a magnetic field such that direction of the current flowing through the conductor is perpendicular to the magnetic field, then a force is exerted on the conductor. Because of this, the conductor moves. But if an electric conductor is moving in a magnetic field or the magnetic field around a stationary conductor is changing, what will happen? In order to find out an answer to this question, research was done by the great scientist Michael Faraday. In the year 1831 Faraday showed that an electric current can be produced in a conductor with the help of a moving magnet.

## Galvanometer

Galvanometer is a sensitive device which works on the same principle as that of an electric motor that we have studied earlier. We can make some electrical measurements with it. A coil is positioned between the pole pieces of a magnet in such a way that the pointer on the galvanometer dial is connected to it. When a small current (for example 1 mA) flows through the coil, the coil will rotate. The rotation will be proportional to the current. Voltmeter and Ammeter also work on the same principle. In galvanometer, the pointer deflects on both the sides of the zero mark depending on the direction of the current.



### 4.14 Galvanometer

Collect the material as shown in figure 4.15. Complete the circuit by connecting the galvanometer. Keep the bar magnet erect in such a way that its north or south pole is just below the copper wire. Now if the wire is kept moving from A  $\longrightarrow$  B, the pointer of the galvanometer gets deflected. This is called Faraday's electromagnetic induction. Now move the magnet with the wire fixed. The Galvanometer pointer still gets deflected.

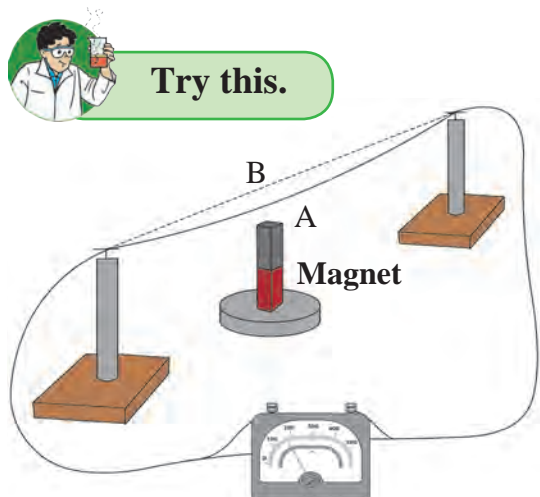

### 4.15 If a conducting wire is kept moving in a magnetic field, a current is produced in it.



**Try this.**

Complete the circuit as shown in figure 4.16a. Discuss about and select the components as required. In this experiment, if we open the plug key and make the current zero in the coil, the pointer of the Galvanometer deflects to a side and quickly comes back to zero. If the current in the coil is started again, the pointer again deflects to the other side and then returns quickly to zero.

Now when the electrical current is flowing through the solenoid coil and the solenoid coil is displaced with respect to the coil, the current is still produced in the coil.

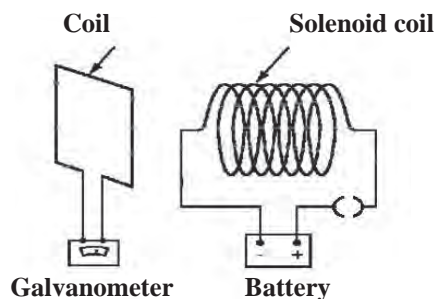

### 4.16 (a) When the current in the solenoid coil is switched on or off

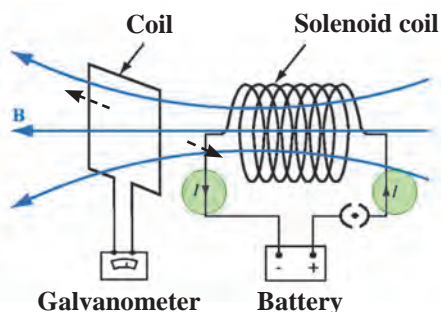

### 4.16 (b) when a current is passing through the solenoid coil and the coil is displaced laterally with respect the coil

What can be inferred from these two experiments?

Even if the solenoid coil is kept stationary, a change in current in the solenoid coil produces a current in the coil. If the solenoid coil is moved towards or away from the coil, we see a deflection in the Galvanometer (fig 4.16c) Also, the faster is the displacement of the solenoid, larger is the deflection of the Galvanometer pointer. If the current in the solenoid coil is changed, a current is produced in the coil or if the solenoid coil is moved towards the coil, then also a current is produced in the coil.

### Faraday's law of induction:

If a current is switched on or off in the solenoid coil, a current is induced in the coil. Such as induction is also observed when the current in the solenoid coil is increased or decreased. Current is induced in the coil when it is moved aside from front of the solenoid. From these experiments it is understood that whenever the number of magnetic lines of force passing through the coil changes, current is induced in the coil. This is known as Faraday's law of induction. The current produced in the coil is called the induced current.

### Fleming's right hand rule :

When will the induced current in the electrical conductor (coil) be maximum? It will be maximum when the direction of motion of the electric conductor is perpendicular to the magnetic field. In order to show the direction of the induced current, Fleming's right hand rule is very useful. Stretch the thumb, the index finger and the middle finger in such a way that they will be perpendicular to each other. In this position, the thumb indicates the direction of motion of the conductor, the index finger the direction of the magnetic field, and the middle finger shows the direction of the induced current. This rule is known as Fleming's right hand rule (fig 4.17).

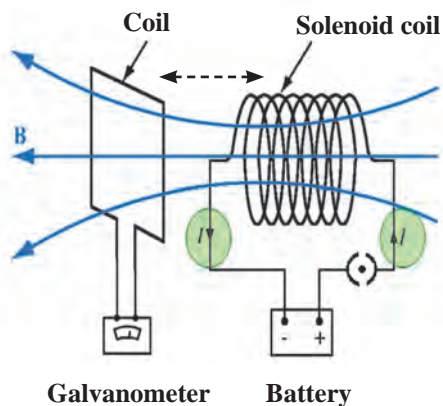

**4.16 c) When a current passing through the solenoid coil and the solenoid coil is displaced longitudinally with respect to the coil**

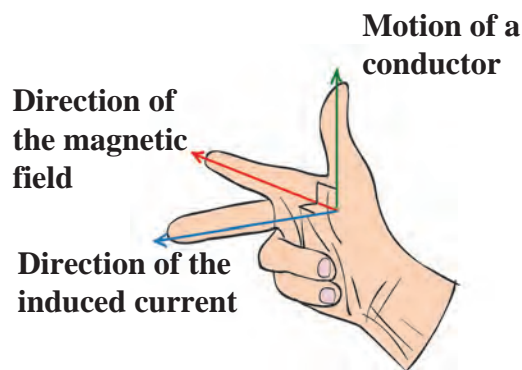

**Motion of a conductor**



**4.17 Fleming's right hand rule**

### Introduction to Scientist

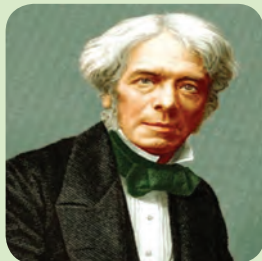

Michael Faraday (1791-1867) was an experimental scientist. He was not formally educated. Teenager Michael started working in a bookbinding shop. While reading books there, he got interested in science. Sir Humphrey Davy appointed him as a laboratory assistant in the Royal Institute London. There he discovered the laws of electromagnetic induction and the laws of electrolysis. Several Universities offered him honorary degree, but Faraday refused to accept such honours.

## Alternating current (AC) and Direct Current (DC)

So far we have learnt about a non oscillatory current flowing in one direction, in a circuit, from the cell to the cell. Such a current is called a direct current (DC) as against a current changing in magnitude and direction after equal intervals of time which is called alternating current (AC).

The direct current can increase, can be stable, or can reduce also, but it is not oscillatory. This is shown graphically in the figure. Alternating current is oscillatory. As shown in the graph (fig 4.19), it increases to a maximum, then reduces to zero and increases to maximum in the other direction and again reduced to zero. (in the figure, magnitudes like -1, -2 have been used to show the reverse direction). The oscillation of the alternating current occurs in a sinusoidal manner with time and hence is shown by the symbol  $\sim$ . Direct current flows in one direction, but the alternating current flows in periodic manner, in one cycle, in forward and reverse directions.

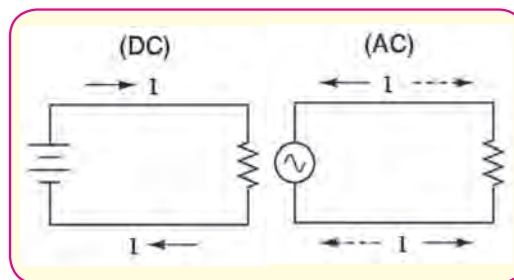

4.18 AC current and DC current

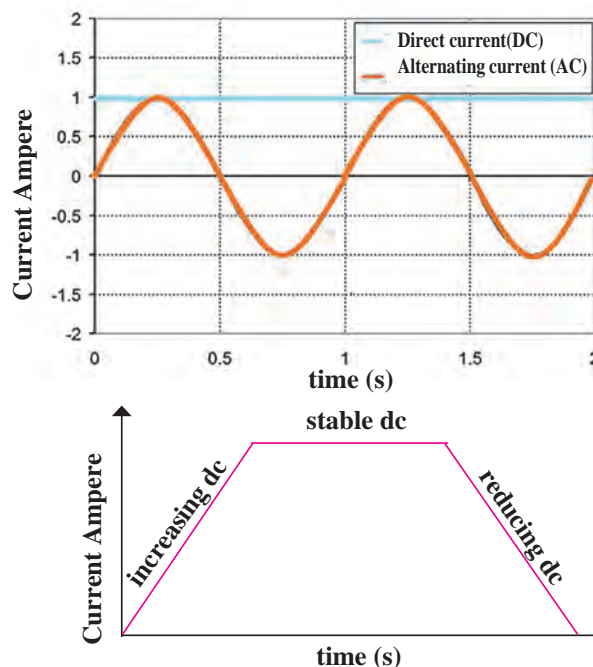

4.19 Alternating current and Direct current (Graphical)

In India, in the power stations generating electricity, one cycle changes in  $\frac{1}{50}$  second i.e. the frequency of AC is 50 Hz (50 cycles per second). When the electric power is transmitted over a long distance, it is beneficial to have it in AC form as it results into minimum power loss during transmission. The home supply is of alternating current (AC). We have learnt in the previous class about the precautions to be taken while using the electricity.

## Electric Generator

We have seen the experiments based on electromagnetic induction. The current produced in these experiments was of very small magnitude. But the same principle can be harnessed for the use of mankind to produce large current. Here, mechanical energy is used to rotate the current carrying coil in a magnetic field, around an axle, thereby producing electricity.

Fig 4.20 shows a copper wire coil ABCD, kept between the two pole pieces of a magnet. The two ends of the coil are connected to the conducting rings  $R_1$  and  $R_2$  via carbon brushes. Both the rings are fixed to the axle, but there is a resistive coating in between the ring and the axle. The axle is rotated with the help of a machine from outside. Because of this, the coil ABCD starts rotating. The stationary carbon brushes  $B_1$  and  $B_2$  are connected to a galvanometer, which shows the direction of current in the circuit. Upon rotating the axle, the branch AB goes up and the branch CD goes down (i.e. the coil ABCD rotates clockwise).

According to Fleming's right hand rule, electric current is produced in the branches AB and CD in the direction.  $A \rightarrow B$  and  $C \rightarrow D$ . Thus, the current flows in the direction  $A \rightarrow B \rightarrow C \rightarrow D$  (as shown by arrows in the figure). In the external circuit, the current flows from  $B_2$  to  $B_1$  through the galvanometer. If instead of one loop coil, a coil consisting of several turns is used, the current of magnitude several times flows. After half rotation, the branch AB takes the place of branch CD and the branch CD takes the position of the branch AB. Therefore, the induced current goes as  $D \rightarrow C \rightarrow B \rightarrow A$ .

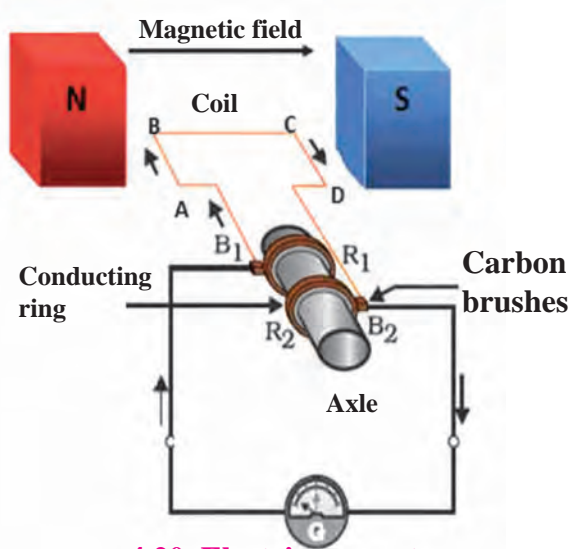

4.20 Electric generator

But, the branch BA is always in contact with the brush  $B_1$  and branch DC in the contact with  $B_2$ . Hence, in the external circuit current flows from  $B_1$  to  $B_2$  i.e. opposite to the previous half rotation. This repeats after every half rotation and alternating current is produced. This is what is called an AC generator.

**What will be required to make a DC generator?** The DC does not change the direction in the external circuit. To achieve this, a split ring is fixed on the axle like a split ring used in electric motor. Because of this arrangement, the branch of the coil going upwards is always in contact with one brush and the branch going downwards is always in contact with the other brush. Hence, the current flows in one direction in the external circuit. This is why this generator is called as a DC generator.



Use your brain power !

Draw the diagram of a DC generator. Then explain as to how the DC current is obtained.

## Exercise

- Tell the odd one out. Give proper explanation.**
  - Fuse wire, bad conductor, rubber gloves, generator.
  - Voltmeter, Ammeter, galvanometer, thermometer.
  - Loud speaker, microphone, electric motor, magnet.
- Explain the construction and working of the following. Draw a neat diagram and label it.**
  - Electric motor
  - Electric Generator(AC)
- Electromagnetic induction means-**
  - Charging of an electric conductor.
  - Production of magnetic field due to a current flowing through a coil.
  - Generation of a current in a coil due to relative motion between the coil and the magnet.
  - Motion of the coil around the axle in an electric motor.
- Explain the difference : AC generator and DC generator.**
- Which device is used to produce electricity? Describe with a neat diagram.**
  - Electric motor
  - Galvanometer
  - Electric Generator (DC)
  - Voltmeter
- How does the short circuit form? What is its effect?**

**7. Give Scientific reasons.**

- Tungsten metal is used to make a solenoid type coil in an electric bulb.
- In the electric equipment producing heat e.g. iron, electric heater, boiler, toaster etc. an alloy such as Nichrome is used, not pure metals.
- For electric power transmission, copper or aluminium wire is used.
- In practice the unit kWh is used for the measurement of electrical energy, rather than joule.

**8. Which of the statement given below correctly describes the magnetic field near a long, straight current carrying conductor?**

- The magnetic lines of force are in a plane, perpendicular to the conductor in the form of straight lines.
- The magnetic lines of force are parallel to the conductor on all the sides of conductor.
- The magnetic lines of force are perpendicular to the conductor going radially outward.
- The magnetic lines of force are in concentric circles with the wire as the center, in a plane perpendicular to the conductor.

**9. What is a solenoid? Compare the magnetic field produced by a solenoid with the magnetic field of a bar magnet. Draw neat figures and name various components.**

**10. Name the following diagrams and explain the concept behind them.**

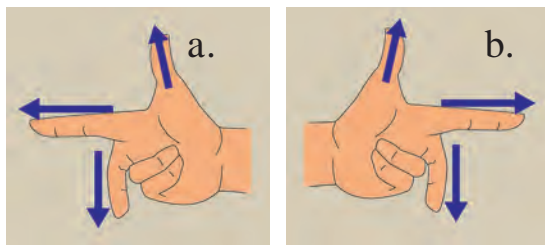

**11. Identify the figures and explain their use.**

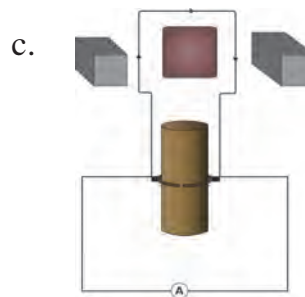
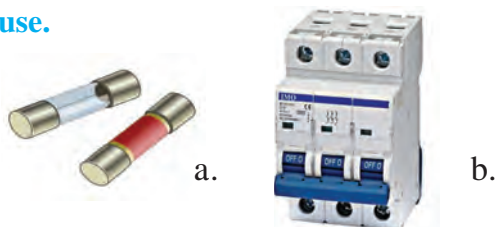

**12. Solve the following example.**

- Heat energy is being produced in a resistance in a circuit at the rate of 100 W. The current of 3 A is flowing in the circuit. What must be the value of the resistance? **(Ans : 11 Ω)**
- Two tungsten bulbs of wattage 100 W and 60 W power work on 220 V potential difference. If they are connected in parallel, how much current will flow in the main conductor? **(Ans : 0.72A)**
- Who will spend more electrical energy? 500 W TV Set in 30 mins, or 600 W heater in 20 mins? **(Ans : TV Set)**
- An electric iron of 1100 W is operated for 2 hrs daily. What will be the electrical consumption expenses for that in the month of April? (The electric company charges Rs 5 per unit of energy). **(Ans : Rs 330)**

**Project**

Under the guidance of your teachers, make a 'free-energy generator'.

